

PAINT PROBLEMS YOU CAN AVOID WITH MEGH[™]

waxes & emulsions



Paints, varnishes and inks properties and waxes application



MAXIMIZE



EFFICIENCY

Mechanism of action in a wax coating (Particle Size)

Mechanism of action in a wax coating

Particle size

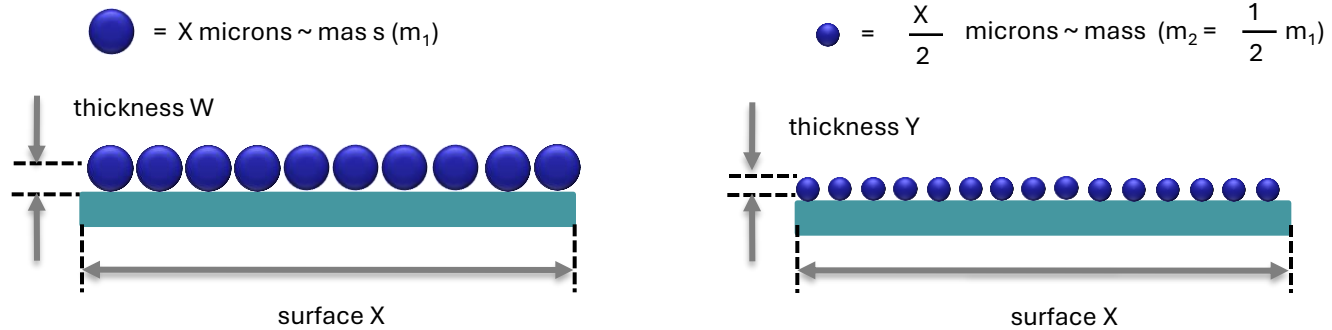

Production system	Average particle size	MEGH's supply
Mill	150 microns	✓
Cooling by heat shock	2 microns	
Emulsions	0,07 microns	✓
Micronization	5 – 20 microns	✓
Dispersion	5 – 20 microns	✓

with a lower wax load is possible to cover the same surface.

“Being a less thickness film, interferes less in the coating aspect.”

Mechanism of action in a wax coating

Mechanism of action in a wax coating

The Blooming Mechanism Molten

Molten wax particles float (or bloom) to the surface.

The coating cools and recrystallization of wax particles takes place, forming a thin but continuous wax-enriched surface layer. Generally, the softer the wax or lower the melting point, the more predominant is the blooming mechanism. The compatibility between the wax emulsion and other formulation components determines the wax migration rate.

Surface migration mechanism

1. The wax particles migrate to the surface.
2. The surface coating cool down and the wax particles re-crystallize , forming a continuous thin film.
- 3. As a rule, as “softener” the wax, lower will be its melting point and the migration will occur faster.**
4. The wax compatibility with the coating formulation is crucial in the migration of the same.

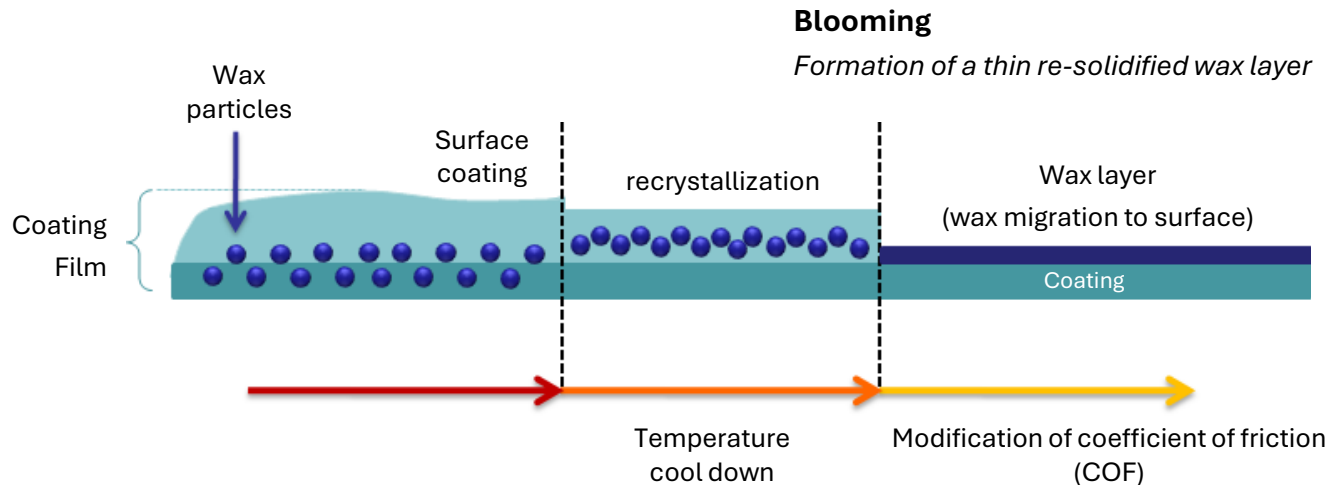

Mechanism of action in a wax coating

The Ball Bearing Mechanism

In this case, solid wax particles migrate individually or protrude through to the surface.

By protruding slightly above the coating surface like ping-pong balls floating on a pool of water, they act as a physical spacer and prevent another surface from coming into close contact.

Hard and high melting point waxes like HDPE, EBS as well as PTFE which exhibits wax like characteristics, operate using this mechanism under certain conditions.

Both the particle density and the extent of protrusion influence the magnitude of the effect.

Once at the surface, the layer of wax particles has the ability to modify the Coefficient of Friction (COF) of the substrate, imparting the desired characteristics.

This explains why waxes are often classified as "Surface Conditioner Additives."

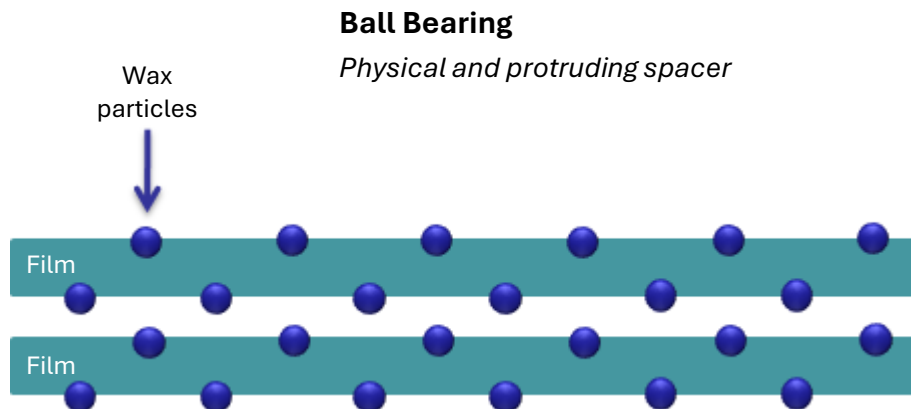

Modification of surface properties at 3% – 5% solids, based on polymer solids

- Slip & Lubricity
- Abrasion resistance
- Anti blocking

Mechanism of action in a wax coating (other important properties)

Mechanism of action in a wax coating



Melting point (MP)

- ✓ When the paint system requires heat curing, it's important that the wax's MP is below of heating cure that will be used.
- ✓ Thereby the wax can melt, migrate to the coating surface, re-crystallize as the surface cools and promote full migration to the surface.



Surface effects

- ✓ To maximize the waxes' surface effects is recommended to achieve a high density of wax (dry base), on the dry paint surface.
- ✓ In the case of emulsions and dispersion the particle size must be the lower as possible and/or as close as possible of paint coating thickness.

1. / 2. Component addition order

- ✓ The component addition order can be a critical factor into the system stability.



pH System

- ✓ In the case of emulsions, the best is the emulsion having a closer paint pH.



Surfactant

- ✓ In the case of emulsions, the surfactant o do tensoativo will influence the final performance.

Mechanism of action in a wax coating



Normatives (standards)

- ✓ depending what kind of paint's application like food contact, etc ; it's necessary to check the wax compatibility with the standards



Wax amount

- ✓ generally determined through application tests.
- ✓ high wax quantities can generate “anchor” problems between the layers.
- ✓ high wax quantities can damage the surface gloss.
- ✓ high wax quantities can “block” the surface.



Contact us and together we will develop the best solution in wax and emulsions to your needs !

web site : www.meghwax.com

sales : vendas@megh.com.br

international sales : comex@megh.com.br

technical department : tecnica@megh.com.br

Change in coating properties using waxes

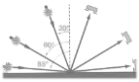

Paint Sheen

- **A paint's gloss, or sheen, is the amount of light the paint reflects.**
- The higher the sheen, the shinier the paint is.
- Choosing the right paint sheen is as important as choosing the right color.
- Some paint finishes hide imperfections, while others highlight them.
- Some types of paint sheens are easily scrubbed, and others will rub off.
- Some paint finishes can withstand lots of touching, while others should not be used in high traffic areas.

Choosing the right type of paint finish sheen

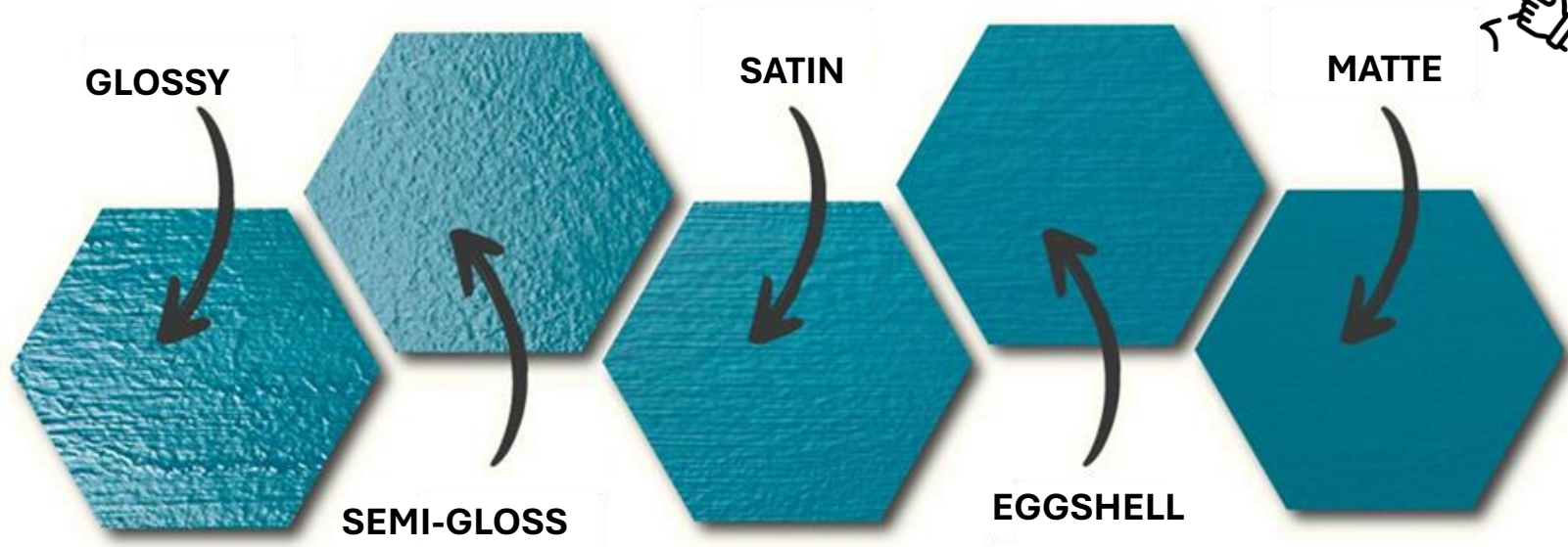

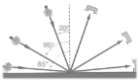

Paint Sheen

- A good example of paint sheen is the house paint, a cheap surface finish.
- It offers an infinite variety of colors and textures and protects the surface.
- Paint is available in different types of paint sheens to suit your requirements.
- **The level of paint sheen you choose has a significant impact on both appearance and serviceability.**
- It also affects the color perception of the occupants.

Type of Sheen	Durability	Scrubability	Hide Imperfections	Applications
Glossy	High	High	Low	Trim, Cabinets, Doors, Furniture
Semi-Gloss	High	High	Low	Kitchen, Trim, Cabinets, Doors
Satin	Medium	Medium	Medium	Bathrooms, Family rooms, Laundry rooms, Toy rooms, Children rooms
Eggshell	Medium-Low	Medium-Low	Medium-High	Bedrooms, Living rooms, Dinning rooms
Matte (Flat)	Low	Low	High	Adult's bedrooms, Ceilings

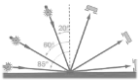

Glossy

- Is the coating ability give gloss to a surface.
- **The gloss property is measure using a glossmeter, being measured at different angles , including 20°, 60°, 85° .**
- The surface gloss although initially give an appreciated visual connotation by the user , is not always a desired property in a paint , varnishes or ink.
- Speaking about sheen is important keep in mind the concepts of:
 - Glossy finish
 - Semi-gloss finish
 - Satin finish
 - Eggshell finish
 - Matte finish

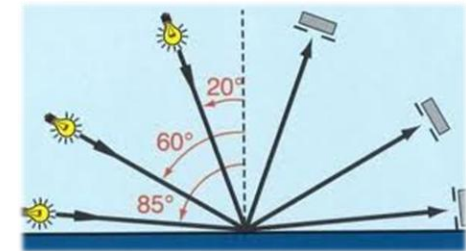

The appropriated equipment to measure sheen is the glossmeter



The desired paint finish can be achieved using different kind of waxes, depending on each case.

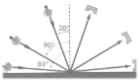

Semi-Gloss

- Is the coating ability give semi-gloss to a surface.
- **The gloss property is measure using a glossmeter, being measured at different angles , including 20°, 60°, 85° .**
- The surface gloss although initially give an appreciated visual connotation by the user , is not always a desired property in a paint , varnishes or ink.
- Speaking about sheen is important keep in mind the concepts of:
 - Glossy finish
 - Semi-gloss finish
 - Satin finish
 - Eggshell finish
 - Matte finish

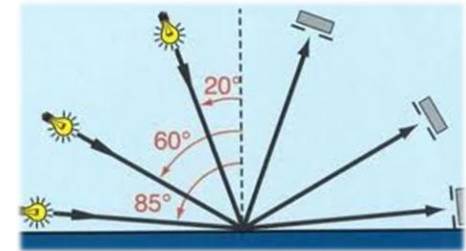

The appropriated equipment to measure sheen is the glossmeter



The desired paint finish can be achieved using different kind of waxes, depending on each case.

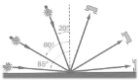

Glossy & Semi-Gloss

Gloss test in a flexographic paint water base with acrylic resin

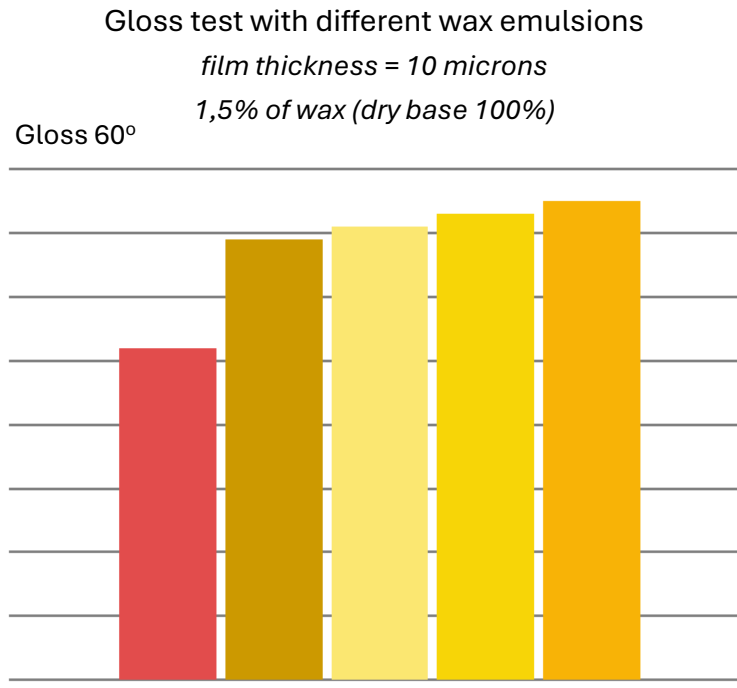





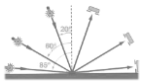







- resin without wax
- emulsion MEGH (Carnauba 25%)
- emulsion MEGH (LDPEOx 25%)
- emulsion MEGH (LLDPEOx 25%)
- emulsion MEGH (HDPEOx 25%)

- According the above test it's possible to improve the gloss in a water base flexographic inks by adding MEGH's wax emulsions.
- **The most appropriate emulsion, in each case will depend on prior tests with different formulations used in the market, to define the gloss level for each formulation**



Glossy & Semi-Gloss

MEGH has a range of micronized waxes to enhance gloss & semi-gloss in varnish coatings:

MEGH Product	Composition		Bio degradable	Bio based
 MEGH [™] PRINT N 101	Carnauba T1 wax (D50 ~ 8μ – 10μ)	100%		
 MEGH [™] PRINT N 103	Carnauba T3 wax (D50 ~ 8μ – 10μ)	100%		
 MEGH [™] PRINT N 120	Modified Rice Bran wax (D50 ~ 8μ – 10μ)	100%		
 MEGH [™] PRINT N 350	Rice Bran wax (D50 ~ 8μ – 10μ)	100%		

Biodegradability test according OECD 301 B normative / Bio-based according ASTM method D6866-24

IMPORTANT: Above we have some examples about MEGH's micronized waxes range, to achieve the whole micronized waxes line, please contact our technical staff or look at our Micronized Waxes brochure for more information's.

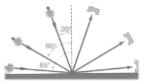

Glossy & Semi-Gloss

MEGH has a range of wax emulsions to enhance gloss & semi-gloss in WB coatings:

MEGH Product	Composition		Bio degradable	Bio based
MEGH™PRINT E 10	LDPEOx emulsion	35%	✓	✗
MEGH™PRINT E 216	LDPEOx emulsion	35%	✓	✗
MEGH™PRINT E 21	LLDPEOx emulsion	35%	✓	✗
MEGH™PRINT E 416	LLDPEOx emulsion	35%	✓	✗
MEGH™PRINT E 619	HDPEOx emulsion (food contact)	35%	✓	✗
MEGH™PRINT E 318	HDPEOx emulsion	35%	✓	✗

MEGH Product	Composition		Bio degradable	Bio based
MEGH™WAX EBA 250	Carnauba T3 emulsion	25%	✓	✓
MEGH™WAX EBA 251	Carnauba T1 emulsion	25%	✓	✓
MEGH™PRINT E 2	Carnauba T3 emulsion (food grade)	30%	✓	✓



Biodegradability test according OECD 301 B normative / Bio-based according ASTM method D6866-24

IMPORTANT : Above we have some examples about MEGH's wax emulsions range, to achieve the whole waxes emulsions line, please contact our technical staff for more information's.

WB = Water based systems



Burnishing resistance

- Paint burnishing happens when a painted surface is subjected to friction usually caused by abrasive cleaners or repeated rubbing or scrubbing to clean it.
- **Burnishing can make a matte paint appear shiny or glossy.**
- This is especially true with darker colors.
- However, that higher pigmentation makes flat paints more susceptible to burnishing.
- Other common causes of burnishing are:
 - Using paint with minimal washability
 - Objects rubbing against the paint (furniture against walls)
 - Using low-quality paints with poor stain and scrub resistance
 - Using the wrong paint in general



Typical wood coating subjected to burnishing

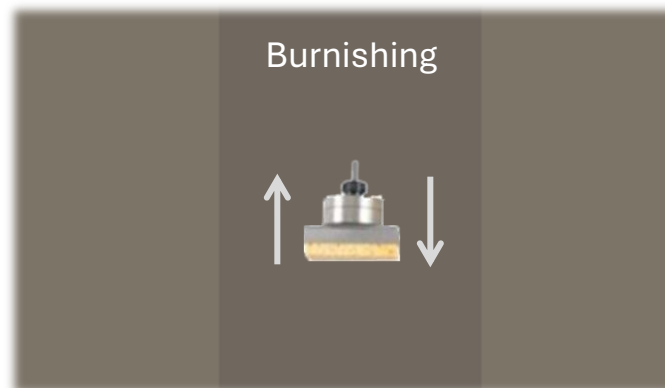







Typical architectural coating subjected to burnishing



Burnishing resistance

MEGH has a range of micronized waxes to enhance burnishing resistance in SB coatings:

MEGH Product	Composition		Bio degradable	Bio based
MEGH™PRINT W 1000 F	Polypropylene wax (D50 ~ 8μ – 10μ)	100%		
MEGH™PRINT N 500 EF	HCO wax (D50 ~ 5μ – 6μ)	100%		
MEGH™PRINT N 500	HCO Bran wax (D50 ~ 8μ – 10μ)	100%		

Biodegradability test according OECD 301 B normative / Bio-based according ASTM method D6866-24











IMPORTANT: Above we have some examples about MEGH's micronized waxes range, to achieve the whole micronized waxes line, please contact our technical staff or look at our Micronized Waxes brochure for more information's.

SB = Solvent based systems



Burnishing resistance

MEGH has a range of wax emulsions to enhance burnishing resistance in WB coatings:

MEGH Product	Composition		Bio degradable	Bio based
MEGH TM PRINT E 5	Polypropylene emulsion	40%		
MEGH TM PRINT E 21	LLDPEOx emulsion	35%		
MEGH TM PRINT E 416	LLDPEOx emulsion	35%		
MEGH TM PRINT E 619	HDPEOx emulsion (food contact)	35%		
MEGH TM PRINT E 318	HDPEOx emulsion	35%		

Biodegradability test according OECD 301 B normative / Bio-based according ASTM method D6866-24

IMPORTANT : Above we have some examples about MEGH's wax emulsions range, to achieve the whole waxes emulsions line, please contact our technical staff for more information's.

WB = Water based systems

Satin Finish or Soft Touch

- Is a coating that gives a "velvety smooth" aspect with a little gloss.
- **Popularly known as ink "with a velvety touch".**
- Also known in English as : butler finish or scratch brush finish.
- Speaking about satin finish is important keep in mind the concepts of:
 - Glossy finish
 - Semi-gloss finish
 - Satin finish
 - Eggshell finish
 - Matte finish

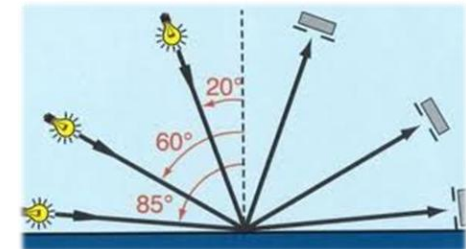







The appropriated equipment to measure sheen is the glossmeter



The desired paint finish can be achieved using different kind of waxes, depending on each case.

Satin Finish or Soft Touch

MEGH has a range of micronized waxes to enhance the Satin Finish/Soft Touch in varnishes & SB coatings:

MEGH Product	Composition		Bio degradable	Bio based
MEGH™PRINT BR 2030 EF	Modified EBS wax (D50 ~ 5μ – 6μ)	100%		
MEGH™PRINT BR 2070	Modified EBS wax (D50 ~ 5μ – 6μ)	100%		
MEGH™PRINT WB 3026	HMP Modified polyolefin wax (D50 ~ 5μ – 6μ)	100%		

Biodegradability test according OECD 301 B normative / Bio-based according ASTM method D6866-24

IMPORTANT : Above we have some examples about MEGH's micronized waxes range, to achieve the whole micronized waxes line, please contact our technical staff or look at our *Micronized Waxes brochure* for more information's.

SB = Solvent based systems



Eggshell finish

- The eggshell sheen, or paint finishes, is similar in appearance to the surface of an egg.
- It is more lustrous than a flat sheen, but less lustrous than satin.
- The eggshell finish has a soft and velvety appearance.
- **Gives the surface where it was applied a touch like "eggshell".**
- Speaking about eggshell finish is important keep in mind the concepts of:



- Glossy finish
- Semi-gloss finish
- Satin finish
- Eggshell finish
- Matte finish

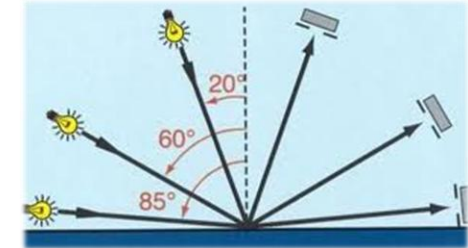

The appropriated equipment to measure sheen is the glossmeter

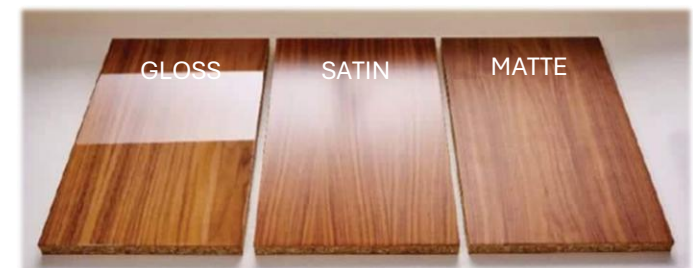

The desired paint finish can be achieved using different kind of waxes, depending on each case.



Eggshell finish

MEGH has a range of micronized waxes to enhance the Eggshell Finish in varnishes & SB coatings:

MEGH Product	Composition		Bio degradable	Bio based
MEGH [™] PRINT BR 2030 EF	Modified EBS wax (D50 ~ 5 μ – 6 μ)	100%		
MEGH [™] PRINT BR 2070	Modified EBS wax (D50 ~ 5 μ – 6 μ)	100%		
MEGH [™] PRINT WB 3026	HMP Modified polyolefin wax (D50 ~ 5 μ – 6 μ)	100%		

Biodegradability test according OECD 301 B normative / Bio-based according ASTM method D6866-24

IMPORTANT : Above we have some examples about MEGH's micronized waxes range, to achieve the whole micronized waxes line, please contact our technical staff or look at our Micronized Waxes brochure for more information's.

SB = Solvent based systems

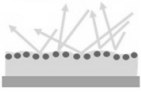

Matting Finish

- In hospitals where an intense gloss may not be interesting, especially in sectors where too much light must be avoided, like the surgical sectors.
- Also used in some industrial environments where the gloss is not a good effect
- **In wood coatings, depending what kind of application are you looking for, a matt surface can be the ultimate desire**
- Speaking about Matting is important keep in mind the concepts of:



- Gloss finish
- Satin finish
- Eggshell finish
- Matte finish



Matt effect in solvent-based systems can be achieved using the MEGHTMPRINT W grades; 3% dosage

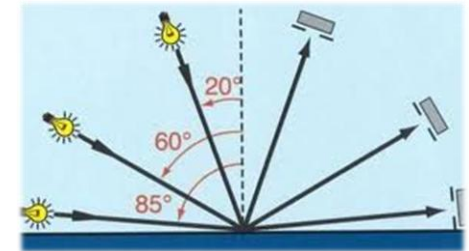

The appropriated equipment to measure sheen is the glossmeter



The desired paint finish can be achieved using different kind of waxes, depending on each case.



Matting effect in solvent-based wood coatings achieve using the MEGHTMPRINT W 400 to W 1000 EF grades; 3% dosage

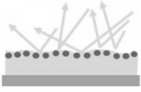

Matting Finish

MEGH has a range of micronized waxes to enhance the Matting Finish in SB & WB coatings:

MEGH Product	Composition		Bio degradable	Bio based
MEGH TM PRINT PM 216	LDPEOx wax (D50 ~ 8μ – 10μ)	100%	✓	✗
MEGH TM PRINT PM 416	LLDPEOx wax (D50 ~ 8μ – 10μ)	100%	✓	✗
MEGH TM PRINT PM 619	HDPEOx wax (D50 ~ 8μ – 10μ)	100%	✓	✗
MEGH TM PRINT PM 318	HDPEOx wax (D50 ~ 8μ – 10μ)	100%	✓	✗
MEGH TM PRINT W 400	Polypropylene wax (D99 ~ 37μ)	100%	✓	✗
MEGH TM PRINT W 500	Polypropylene wax (D99 ~ 31μ)	100%	✓	✗
MEGH TM PRINT W 1000 F	Polypropylene wax (D99 ~ 20μ)	100%	✓	✗
MEGH TM PRINT B 1110 EF	EBS wax (D50 ~ 5μ – 6μ)	100%	✓	✓
MEGH TM PRINT PBW 94101	Modified Polyolefin wax (D50 ~ 8μ – 10μ)	100%	✓	✗



Biodegradability test according OECD 301 B normative / Bio-based according ASTM method D6866-24

IMPORTANT: Above we have some examples about MEGH's micronized waxes range, to achieve the whole micronized waxes line, please contact our technical staff or look at our Micronized Waxes brochure for more information's.

SB = Solvent based systems | **WB** = Water based systems



Texture – General aspects

- **Texture in a coating is the property of surface to appears with a rough & coarse aspect due to addition of different kind of texture additives.**
- We can differentiate the textures according their final applications:
 - Wood coatings Textures
 - Industrial coatings textures
 - Powder coating Textures
 - Architectural coatings textures
- In those different kind of paints and coatings the texture aspect as so as the texture additives will work specifically for each case.



*Typical Wood coating
Texture*



*Typical Industrial coating
Texture*



*Typical Powder coating
Texture*



*Typical Architectural
coating Texture*



Texture – Wood Coatings

- Wood coatings texture describes how a wood surface looks and feels.
- **Wood coatings can add texture to the wood, and the texture can be enhanced by using different types of finishes.**
- Wood coating texture is related to:
 - The uniformity of a wood surface's appearance
 - The direction of wood elements, such as straight, spiral, or wavy
 - How a piece of wood feels
 - The number of processes a wood surface has undergone
- **Micronized polypropylene designed to produce unique texturizing effects in paints and coatings, in all solvent-borne coating systems.**
- Some of polypropylene wax advantages:
 - High melting point
 - Low density (will reduce or eliminate settling)
 - Insolubility
 - Excellent durability

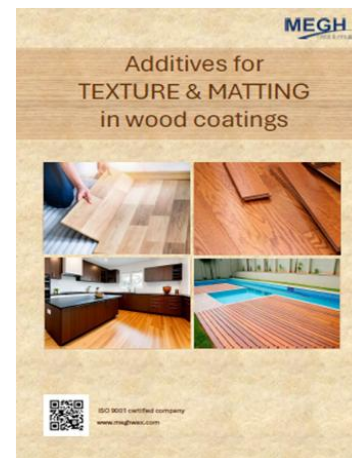





Click on the above QR code and learn a little more about our micronized PP wax range in wood coatings applications



Texture – Wood Coatings

MEGH has a range of micronized waxes to enhance the texture in SB & WB wood coatings:

MEGH Product	Composition		Bio degradable	Bio based
MEGH [™] PRINT W series	Polypropylene waxes (D90 ~ 150 μ – 44 μ)	100%		
MEGH [™] PRINT PMT series	Oxidized polyolefin waxes (D90 ~ 150 μ – 44 μ)	100%		

Biodegradability test according OECD 301 B normative / Bio-based according ASTM method D6866-24

IMPORTANT: Above we have some examples about MEGH's micronized waxes range, to achieve the whole micronized waxes line, please contact our technical staff or look at our Micronized Waxes brochure for more information's.

SB = Solvent based systems | **WB** = Water based systems



Texture – Industrial Coatings

- Industrial coatings texture describes how an industrial surface looks and feels.
- **Industrial coatings can add texture to the coating, and the texture can be enhanced by using different types of finishes.**
- Industrial coating texture is related to:
 - The uniformity of an industrial coating surface's appearance
 - The direction of industrial coating elements, such as straight, spiral, or wavy
 - How a piece of industrial coating feels
 - The number of processes an industrial coating surface has undergone
- **Micronized polypropylene designed to produce unique texturizing effects in paints and coatings, in all solvent-borne coating systems.**
- Some of polypropylene wax advantages:
 - High melting point
 - Low density (will reduce or eliminate settling)
 - Insolubility
 - Excellent durability



Click on the above QR code and learn a little more about our micronized PP wax range in industrial coatings applications



Texture – Industrial Coatings

MEGH has a range of micronized waxes to enhance the texture in SB & WB industrial coatings:

MEGH Product	Composition		Bio degradable	Bio based
MEGH [™] PRINT W series	Polypropylene waxes (D99 ~ 150μ – 44μ)	100%		
MEGH [™] PRINT PMT series	Oxidized polyolefin waxes (D99 ~ 150μ – 44μ)	100%		
MEGH [™] PRINT BM series	EBS waxes (D99 ~ 80μ – 44μ)	100%		

Biodegradability test according OECD 301 B normative / Bio-based according ASTM method D6866-24

IMPORTANT: Above we have some examples about MEGH's micronized waxes range, to achieve the whole micronized waxes line, please contact our technical staff or look at our Micronized Waxes brochure for more information's.

SB = Solvent based systems | **WB** = Water based systems



Texture – Powder Coatings





- **Textured powder coating is a specialized surface finish that adds a tactile texture to the coated item, providing both functional and aesthetic benefits.**
- How to Choose the Right Textured Powder Coating for Your Project?
 - Consider the Application
 - Aesthetic Preferences
 - Material Compatibility
 - Functional Needs
- Due to the high process temperature of a powder coating, the texture additives must have a high melting point, otherwise they will melt during the process.
- **Some high melting point micronized materials capable to be use as texture in powder coatings:**
 - **PTFE**
 - **Modified Polyolefin waxes**
 - **Polyamide**





Texture – Powder Coatings

MEGH has a range of micronized waxes to enhance the texture in powder coatings:

MEGH Product	Composition		Bio degradable	Bio based
MEGH [™] PRINT FR 1090 M 400	Modify synthetic wax (D90 ~ 30 μ – 35)	100%		
MEGH [™] PRINT R 1500	PTFE (D90 ~ 20 μ – 25 μ)	100%		

Biodegradability test according OECD 301 B normative / Bio-based according ASTM method D6866-24

IMPORTANT : Above we have some examples about MEGH's micronized waxes range, to achieve the whole micronized waxes line, please contact our technical staff or look at our *Micronized Waxes brochure* for more information's.



Texture – Architectural Coatings

- Texture in architectural coatings can refer to the surface pattern or quality of a material, or to a coating that creates a textured appearance
- **In modern architecture, texture plays a critical role in defining the character and atmosphere of a space.**
- It influences both visual perception and tactile experience.
- **Architectural coatings can have a variety of textures, including:**
 - **Sand texture paint**
 - **Stucco**
 - **Terracotta**
 - **Popcorn texture**
 - **Orange peel texture**
 - **Aggregate finish**



among a lot of different possibilities according the technology available in each region.

- In architectural textures the water resistance is an important issue to achieve.
- This resistance can be seen through the “**Dew effect**”.
- **Paraffin wax & low melting point Ester waxes emulsions** can guarantee an excellent “dew effect” to architectural textures, specially in external architectural textures where the weather resistance must be more severe.

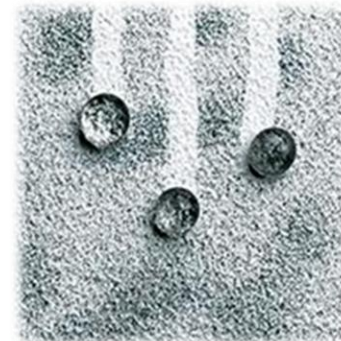











Dew effect



Texture – Architectural Coatings

MEGH has a range of wax emulsions to enhance texture in WB architectural coatings:

MEGH Product	Composition		Bio degradable	Bio based
MEGH TM PRINT E 12	Paraffin emulsion	45%		
 MEGH TM WAX EEW 5030	Natural Ester wax emulsion	45%		
 MEGH TM SPERSE BIO 59138	Vegetable Ester wax dispersion	45%		
 MEGH TM SPERSE BIO 59238	Vegetable Ester wax dispersion	45%		

Biodegradability test according OECD 301 B normative / Bio-based according ASTM method D6866-24

IMPORTANT : Above we have some examples about MEGH's waxes emulsions range, to achieve the whole waxes emulsions line, please contact our technical staff for more information's.

WB = Water based systems

Hydrophobicity (Hydrophobic effect)

- **Is the coating ability does not absorb water**, either from rain, environment humidity or even because washed areas around the place the paint was applied.

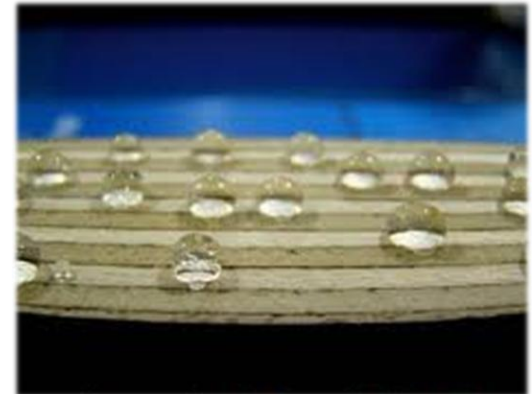

natural effect found in plants and that occurs due the intrinsic natural wax layer

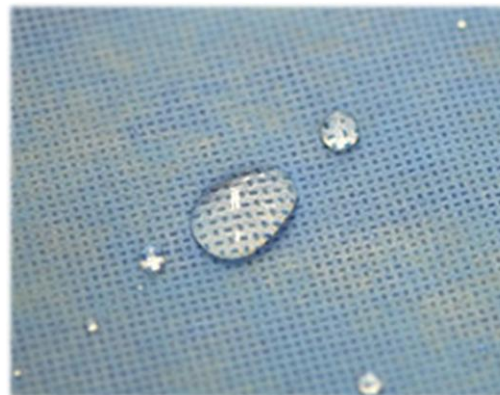

Dew effect



Hydrophobicity (Hydrophobic effect)

- A few of laboratory tests can be run to understand the coating hydrophobicity and to help define the best additives to use it.
 - **Water contact angle measurements (ASTM D5946)**
A drop of water is placed on a surface, and the drop water contact angle in paper surfaces is measure.
 - **COOB test (ASTM D3285)**
Measure if the test material has strong water absorption and moisture retention properties or if the test material has the property of resisting water penetration and moisture is not easy to remain.
 - **Water absorption (resistance) test (ASTM D3285)**
Measures how much water a material absorbs when submerged in water.
 - **MVTR (Moisture & Vapor Transmission rate) test (ASTM F1249)**
At a selected temperature and humidity, a barrier film is sealed between a wet chamber and dry chamber. A pressure modulated sensor measures moisture transmitted through the material tested.



*Water
contact angle
measurements*



*COOB Tester
Water absorption
measurements*







MVTR Tester



Hydrophobicity (Hydrophobic effect)

MEGH has a range of wax emulsions & dispersions to enhance hydrophobicity in WB coatings:

MEGH Product	Composition		Bio degradable	Bio based
MEGH™PRINT E 12	Paraffin emulsion	45%	✗	✗
 MEGH™WAX EEW 5030	Natural Ester wax emulsion	45%	✓	✓
MEGH™SPERSE A 1540	Modified Polyethylene dispersion	40%	✓	✗
 MEGH™SPERSE BIO 59138	Vegetable Ester wax dispersion	45%	✓	✓
 MEGH™SPERSE BIO 59238	Vegetable Ester wax dispersion	45%	✓	✓
 MEGH™SPERSE BIO 9645	Vegetable Rice Bran wax dispersion	45%	✓	✓

Vegetable Ester wax emulsion = Ester waxes based on vegetable raw materials from different sources like soy, palm, sunflower, rapeseed, coconut sources; alone or in mixtures or reactions among them.

Biodegradability test according OECD 301 B normative / Bio-based according ASTM method D6866-24

IMPORTANT : Above we have some examples about MEGH's waxes emulsions & dispersions range, to achieve the whole waxes emulsions & dispersions line, please contact our technical staff for more information's.

WB = Water based systems

Typical problems related to low water resistance in coatings

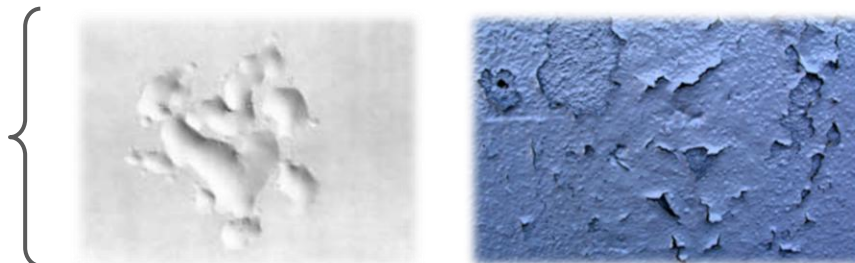



Water Drop Resistance



Special emulsions to water resistance in coatings :

- Through a MEGH's new proprietary technology in oxidized and grafted waxes we can offer the market a full line of special wax emulsions to increase the water resistance in coatings.
- Manufacture with a modern emulsion process , MEGH emulsions can guarantee a higher quality in water resistance , with a greater hydrophobicity than the traditional nonionic PE emulsions in the market.

Water drop resistance test

check the time, in seconds, that a water drop needs to damage a coating of wax emulsion

specialty wax emulsion (25% solids)

Film thickness of 100 microns

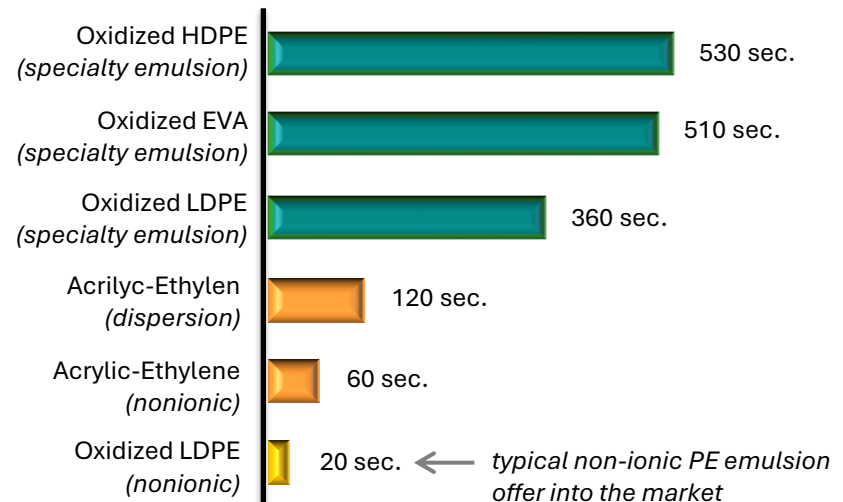
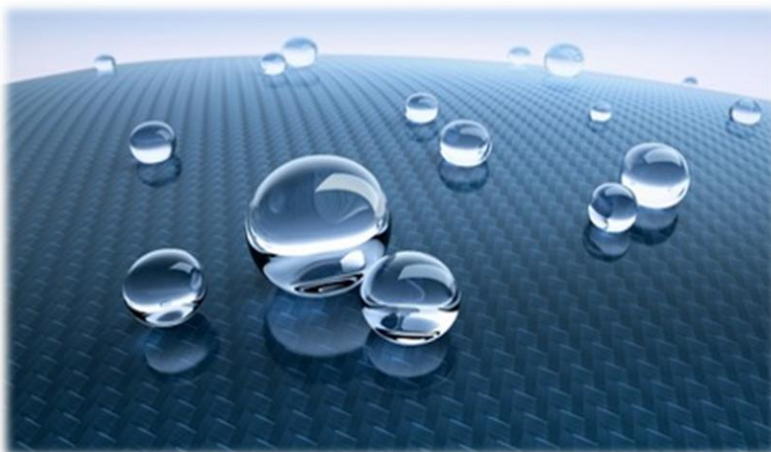



Water Drop Resistance

MEGH has a range of wax emulsions & dispersions to enhance Water Drop Resistance in WB coatings:

MEGH Product	Composition		Bio degradable	Bio based
MEGH TM PRINT E 318	HDPEOx emulsion	35%		
MEGH TM PRINT E 128	EVAOx emulsion	35%		
MEGH TM PRINT E 21	LLDPEOx emulsion	35%		
MEGH TM SPERSE AC 5120 A 25	EAA dispersion	25%		
MEGH TM WAX AC 540 N 30	EAA emulsion	30%		

Biodegradability test according OECD 301 B normative / Bio-based according ASTM method D6866-24

IMPORTANT : Above we have some examples about MEGH's waxes emulsions range, to achieve the whole waxes emulsions line, please contact our technical staff for more information's.

WB = Water based systems



Scrub Resistance

- **Scrub resistance is a measure of how well a coating can resist wear and tear from chemicals, abrasive materials, and repeated cleaning.**
- It's important for coatings to have good scrub resistance so they maintain their appearance and physical properties after being washed.

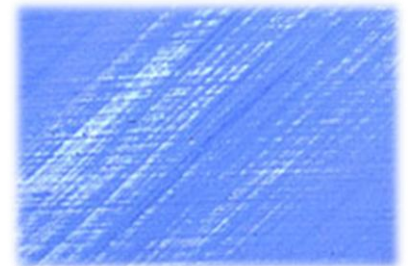
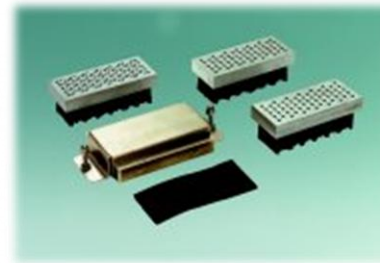

Scrub Abrasion and Washability Tester





Scrub Resistance



Scrub Abrasion and Washability Tester

- According ABRAFATI normatives, the scrub resistance specifications are :

Matt Paint

Economical line (2^a line) minimal 100 cycles of scrub with detergent

Standard paint minimal 40 cycles of scrub with abrasive paste

Premium paint minimal 100 cycles of scrub with abrasive paste

Those normatives are valued to matt paints, in the semi-gloss we still don't have an ABRAFATI normative.

Scrub Resistance Test

ABNT NBR 15078

Typical economical paint formulation (2^a line)

nonionic LDPE emulsion (35% solids)

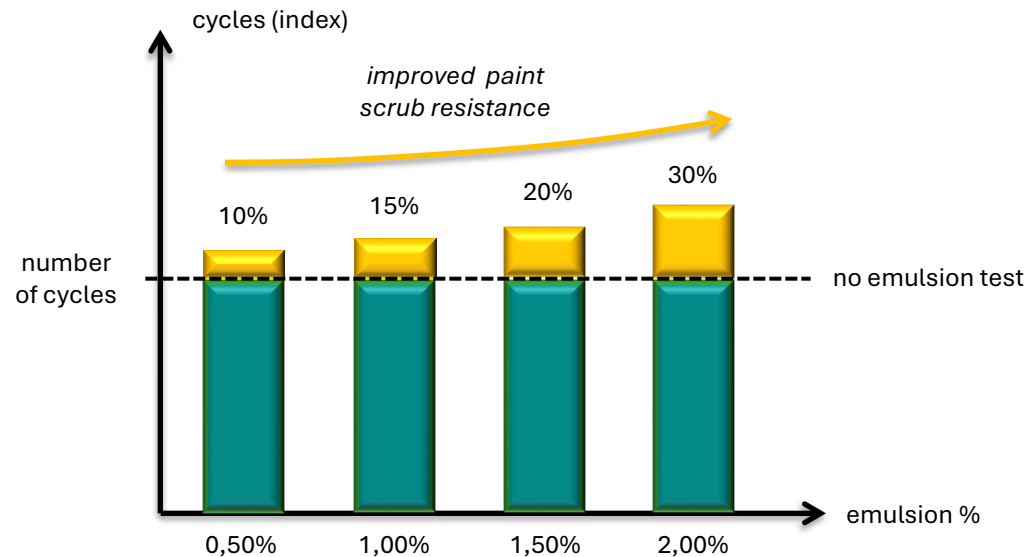



Scrub Resistance

MEGH has a range of wax emulsions & dispersions to enhance Scrub Resistance in WB coatings:

MEGH Product	Composition		Bio degradable	Bio based
MEGH [™] PRINT E 10	LDPEOx emulsion	35%		
MEGH [™] PRINT E 216	LDPEOx emulsion	35%		
MEGH [™] PRINT E 21	LLDPEOx emulsion	35%		
MEGH [™] PRINT E 416	LLDPEOx emulsion	35%		
MEGH [™] PRINT E 619	HDPEOx emulsion (food contact)	35%		
MEGH [™] PRINT E 318	HDPEOx emulsion	35%		

Biodegradability test according OECD 301 B normative / Bio-based according ASTM method D6866-24

IMPORTANT : Above we have some examples about MEGH's waxes emulsions and dispersions range, to achieve the whole waxes emulsions line, please contact our technical staff for more information's.

WB = Water based systems



Weather resistance

- **Weather resistance is the ability of a material or structure to withstand the effects of weather conditions over time.**
- Weather-resistant materials can resist damage from:
 - **Rain**
 - **Wind**
 - **Sun**
 - **Temperature**
- Examples of weather-resistant materials:
 - Treated wood: Can be used to enhance weather resistance
 - Galvanized metal: Can be used to enhance weather resistance
 - External Architecture wall paints





Moisture resistance

- Is the surface ability to resist to swelling, blistering, mold or any other damage caused by exposure to rain.
- **Also know as protective coatings.**
- **The protective coating is a coating that is placed over a surface to shield it against exterior atmosphere, which may harm an object or part's function or integrity.**
- Protective coatings are used in household goods, heavy equipment, marine, automobile, infrastructure and oil & gas sectors.
- Such coatings, when applied periodically, provide long-range security, which enhances a structure's service life.
- These coatings are utilized to shield and enhance aesthetical appearance of metals, plastics, and objects made of wood.





Weather & Moisture resistance

MEGH has a range of micronized waxes to enhance weather & moisture resistance in SB & WB coatings:

MEGH Product	Composition		Bio degradable	Bio based
MEGH [™] PRINT E 12	Paraffin emulsion	45%		
MEGH [™] WAX EEW 5030	Natural Ester wax emulsion	45%		
MEGH [™] SPERSE A 1540	Modified Polyethylene dispersion	40%		
MEGH [™] SPERSE BIO 59138	Vegetable Ester wax dispersion	45%		
MEGH [™] SPERSE BIO 59238	Vegetable Ester wax dispersion	45%		
MEGH [™] SPERSE BIO 9645	Vegetable Rice Bran wax dispersion	45%		

Biodegradability test according OECD 301 B normative / Bio-based according ASTM method D6866-24

IMPORTANT: Above we have some examples about MEGH's micronized waxes range, to achieve the whole micronized waxes line, please contact our technical staff or look at our Micronized Waxes brochure for more information's.

SB = Solvent based systems | **WB** = Water based systems



Antiblocking

- Is the coating ability to prevent adhesion to other substrates placed on it, either immediately after the manufacture process or after a storage time.

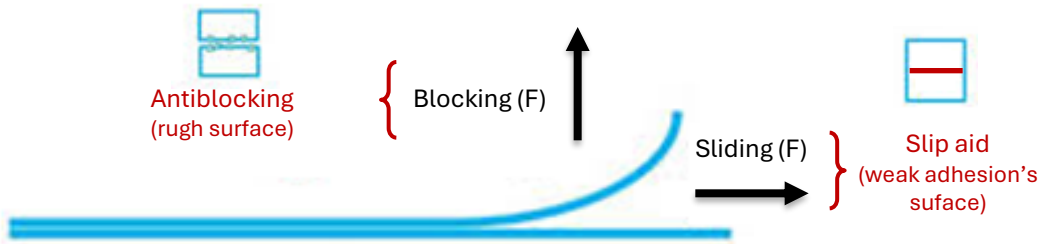

Cardboard boxes stacking and logistics



Can Coating Manufacture



FEDEX / UPS



Freeze Food



Printing and Handling of magazines



Fruits



Flexible Packaging



Antiblocking

MEGH has a range of micronized waxes and wax dispersions to enhance antiblocking in SB & WB coatings:

MEGH Product	Composition		Bio degradable	Bio based
MEGH [™] PRINT W 1000 F	Polypropylene wax (D50 ~ 8μ – 10μ)	100%	✓	✗
MEGH [™] PRINT B 1110 EF	EBS wax (D50 ~ 5μ – 6μ)	100%	✓	✓
MEGH [™] PRINT B 1110	EBS wax (D50 ~ 8μ – 10μ)	100%	✓	✓
MEGH [™] PRINT PB 0475 EF	Modified polyolefin wax (D50 ~ 5μ – 6μ)	100%	✓	✓
MEGH [™] PRINT PB 0475	Modified polyolefin wax (D50 ~ 8μ – 10μ)	100%	✓	✓
MEGH [™] PRINT PB 0417 EF	Modified polyolefin wax (D50 ~ 5μ – 6μ)	100%	✓	✓
MEGH [™] SPERSE A 1230	EBS wax dispersion	31%	✓	✓

Biodegradability test according OECD 301 B normative / Bio-based according ASTM method D6866-24

IMPORTANT : Above we have some examples about MEGH's micronized waxes and wax dispersions range, to achieve the whole micronized waxes and wax dispersions line, please contact our technical staff or look at our Micronized Waxes brochure for more information's.

SB = Solvent based systems | **WB** = Water based systems



Coefficient of friction (COF) – Slip

- **Coefficient of friction (COF) is a kind of “slip” measure, an important property in printing inks & packaging application.**
- An appropriated slip is important to avoid problems in the printing machine rolls & stacking boxes.
- The COF value has an upper and lower limit.
- **In printing Inks that means, one surface with much slip (low COF), will not print good, while a surface with low slip (high COF) will also present printing problems.**

Typical Flexographic water base ink
(film applied by hand proofer - roller test)

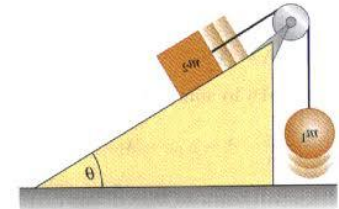
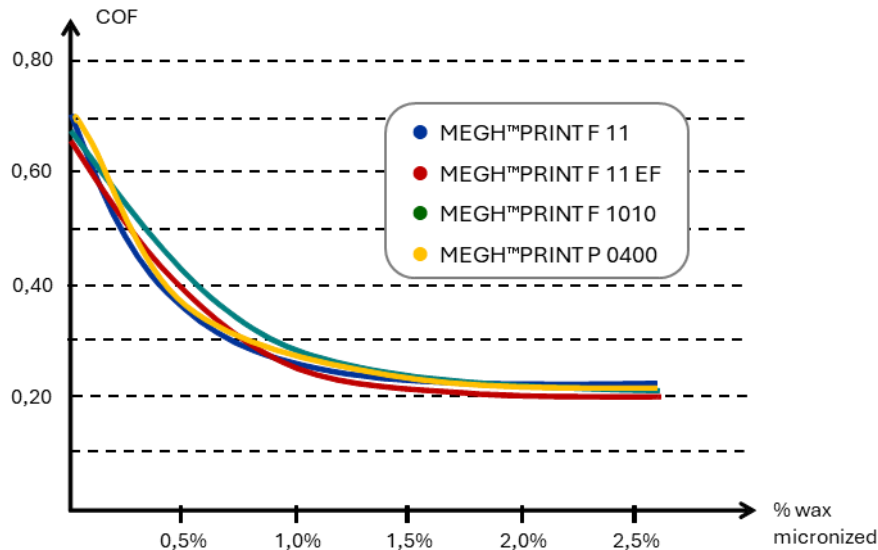

static COF



dynamic COF



Coefficient of friction (COF) – Slip

MEGH has a range of micronized waxes to achieve the desired COF in SB coatings:

MEGH Product	Composition		Bio degradable	Bio based
MEGH™PRINT F 11 EF	Synthetic wax (D50 ~ 5μ – 6μ)	100%	✓	✗
MEGH™PRINT F 11	Synthetic wax (D50 ~ 8μ – 10μ)	100%	✓	✗
MEGH™PRINT F 1010	Synthetic wax (D50 ~ 8μ – 10μ)	100%	✓	✗
MEGH™PRINT P 0400	Polyolefin wax (D50 ~ 8μ – 10μ)	100%	✓	✗
MEGH™PRINT PR range	Modified Polyolefin wax (D50 ~ 8μ – 10μ)	100%	✓	✗

MEGH Product	Composition		Bio degradable	Bio based
 ECOWAX™PRINT P 0400	Polyolefin wax (D50 ~ 8μ – 10μ)	100%	✓	✓

Biodegradability test according OECD 301 B normative / Bio-based according ASTM method D6866-24

IMPORTANT : Above we have some examples about MEGH’s micronized waxes range, to achieve the whole micronized waxes line, please contact our technical staff or look at our Micronized Waxes brochure for more information’s.

SB = Solvent based systems



Anti Slip effect (slip control)

- **Sometimes slip is an undesirable effect in a coating an important property to be avoid, for example, in printing inks & packaging application.**
- Printing inks on packaging stacked on top of each other must have low slippage, otherwise they may slip during transportation and storage.
- High traffic areas, like hospitals, shopping centers, airports can not present to much slip as a safety issue.



Typical Flexographic water base ink
(film applied by hand proofer - roller test)

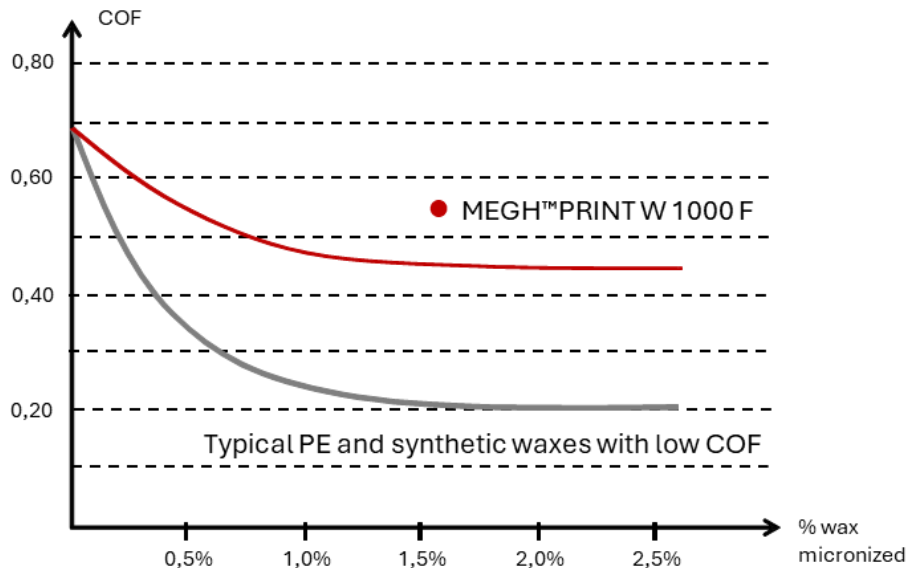

Anti slip epoxy floor



Anti Slip effect (slip control)

MEGH has a range of micronized & emulsion waxes to achieve the desired anti slip in WB & SB coatings:

MEGH Product	Composition		Bio degradable	Bio based
MEGH [™] PRINT W 1000 F	Polypropylene wax (D50 ~ 8μ – 10μ)	100%		

MEGH Product	Composition		Bio degradable	Bio based
MEGH [™] PRINT E 5	Polypropylene emulsion	40%		

Biodegradability test according OECD 301 B normative / Bio-based according ASTM method D6866-24

IMPORTANT : Above we have some examples about MEGH's micronized and emulsion waxes range, to achieve the whole micronized waxes line, please contact our technical staff or look at our Micronized Waxes brochure for more information's.

SB = Solvent based systems | **WB** = Water based systems



Non-Skid

- Non-skid coatings are applied to surfaces to improve friction and prevent slips and falls.
- **In addition to providing anti-slip, the non-skid system has a certain texture.**
- **How a non-skid coating works :**
- **Friction coefficient:** The friction coefficient of the coating determines its anti-slip properties. A coating is considered anti-slip if its friction coefficient is greater than 0.45.
- **Particles:** Irregularly shaped particles are often added to the coating to increase friction.
- **Texture:** The particles create a rough texture that prevents sliding.



Without Non-skid

With Non-skid



Non-Skid

MEGH has a range of micronized waxes to enhance the non-skid system in SB & WB coatings:

MEGH Product	Composition		Bio degradable	Bio based
MEGH [™] PRINT W series	Polypropylene waxes (D99 ~ 150μ – 44μ)	100%		
MEGH [™] PRINT PMT series	Oxidized polyolefin waxes (D99 ~ 150μ – 44μ)	100%		
MEGH [™] PRINT BM series	EBS waxes (D99 ~ 80μ – 44μ)	100%		

Biodegradability test according OECD 301 B normative / Bio-based according ASTM method D6866-24

IMPORTANT : Above we have some examples about MEGH's micronized waxes range, to achieve the whole micronized waxes line, please contact our technical staff or look at our Micronized Waxes brochure for more information's.

SB = Solvent based systems | **WB** = Water based systems



Abrasion resistance

- Abrasion resistance is a coating's ability to withstand wear and tear from rubbing, scraping, or erosion.
- **It's a key property of a coating that determines its durability and longevity.**
- Abrasion resistance is a basic factor in the durability of a coating.
- Abrasion resistant coatings are applied to a substrate intended to prevent mechanical damage that can result in surface imperfections.
- They are widely used to reduce or eliminate wear and thus, extend the lifetime of coated parts.

example of abrasion test:

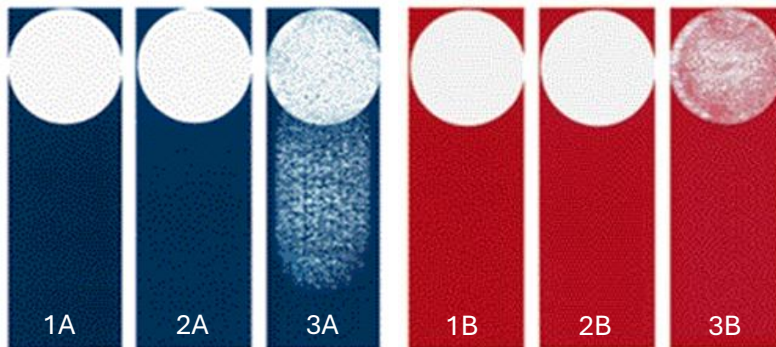

Quantant testing machine



abrasion resistance results (Quantant testing machine) of 2 flexographic inks with the following wax content :

1A / 1B = 1 % of MEGH[™]PRINT P 0400 **dispersion** (dry base, 200 abrasion cycles)

2A / 2B = 1 % of MEGH[™]PRINT P 0400 **micronized wax** (dry base, 200 abrasion cycles)

3A / 3B = without wax (dry base, 200 abrasion cycles)



Taber abrasion resistance (Wear resistance)

- Taber abrasion resistance is a measure of how well a coating can resist wear and tear from rubbing, scraping, or erosion.
- **The Taber abrasion test is used to determine the resistance of a variety of materials, including paints, lacquers, textiles, and plastics.**
- The test measures the loss in weight at a specified number of abrasion cycles
- It can also measure the loss in weight per cycle
- It can measure the number of cycles needed to remove a unit amount of coating thickness

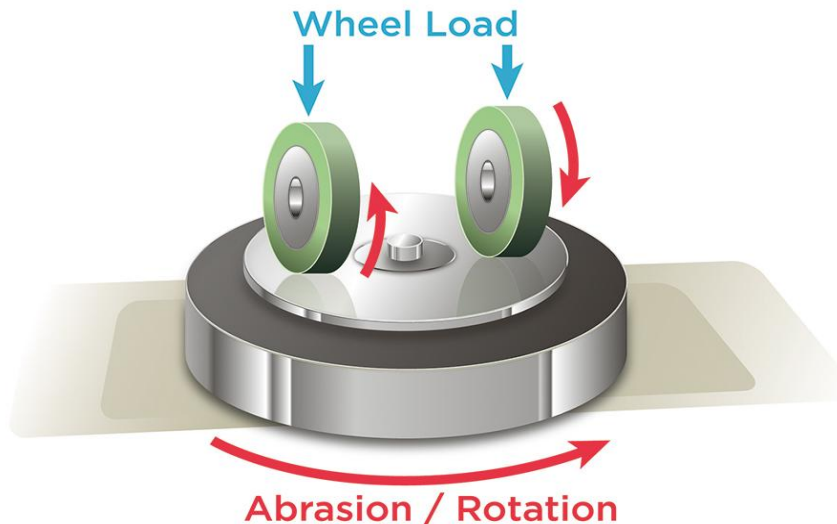

Taber testing machine



Taber abrasion resistance (Wear resistance)

- Wear resistance in a coating is the ability of the coating to prevent damage from friction, abrasion, and other types of wear.
- **Wear-resistant coatings can help extend the life of components and reduce maintenance costs.**
- For example, in alkyd varnish, when the amount of polypropylene wax is 1,5%, the anti-wear value of the coating film is doubled, and when the amount is 3%, the anti-wear value is increased by 5 times.



Typical alkyd varnish formulation
(Wear resistance value)

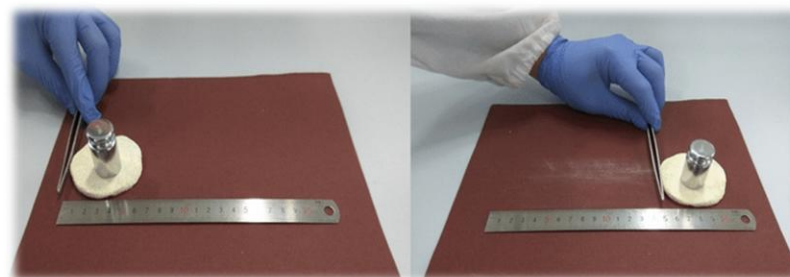
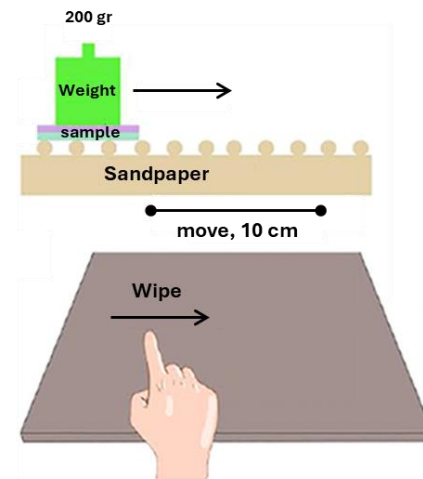
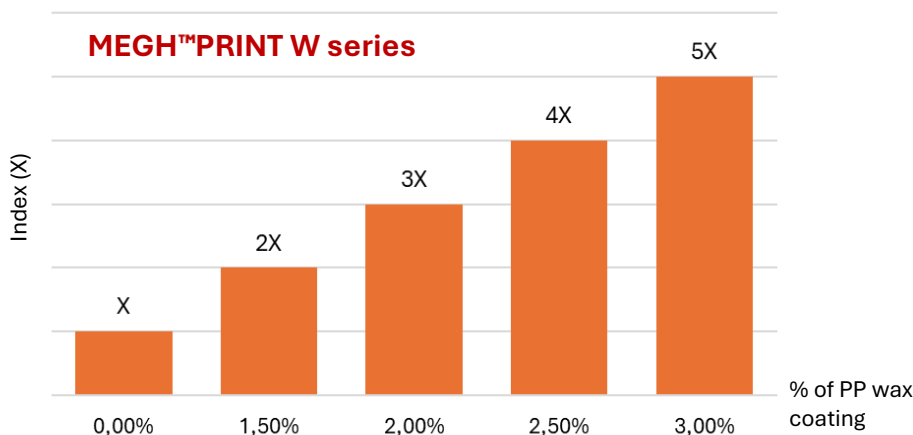



Taber abrasion resistance (Wear resistance)

- **Acrylic urethane paint** is a type of fast-dry protective coating widely used in a variety of industrial applications, such as floor paint, auto paint, and others.
- When used as floor paint, it can serve areas with heavy foot and rubber-wheel traffic, such as walkways, curbs and parking lots.
- **Acrylic urethane floor paints have a recommended dry film thickness of 37,5 – 50,0 μ .**
- **The aggressive abrasion process by Taber Abraser** can quickly wear through the acrylic urethane coating and create mass loss to the substrate leading to substantial errors in the calculation of the paint weight loss.

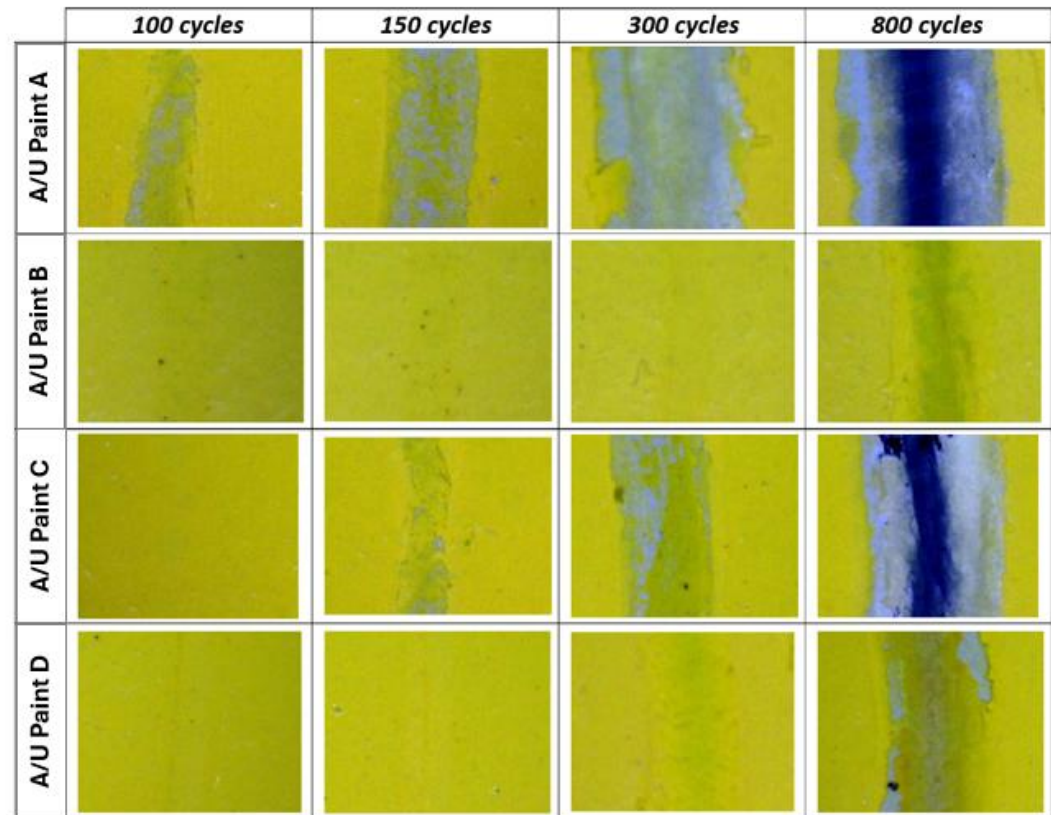

Rub resistance

- **The Mechanical resistance, or Rub resistance, is the test commonly used to measuring the abrasion resistance in paints, varnishes and printing inks.**
- Although exist the Quartant test machine and the Taber test machine that can be also used for the same purpose.
- The mechanical resistance or rub resistance can be measure by 2 ways :
 - Dry rub resistance is the coating ability to withstand a mechanical action on its surface.
 - Wet rub resistance is the coating ability to resist to softening or even peeling due the act of rubbing its surface in a wet condition.
- The most often equipment used to measure the rub resistance is the Sutherland 2000, as below :

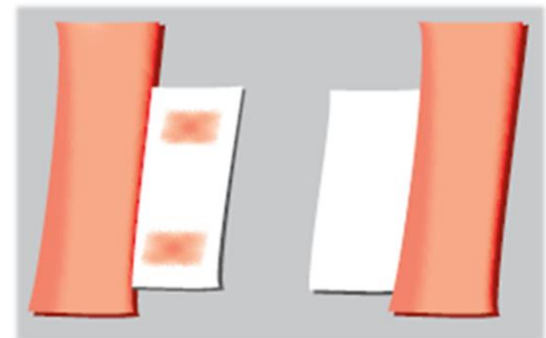

Rub resistance

Sutherland Rub Resistance test

(100 cycles, weight = 4 lb.)

film thickness = 10 microns

Typical Flexographic ink formulation

Reference
(without wax)

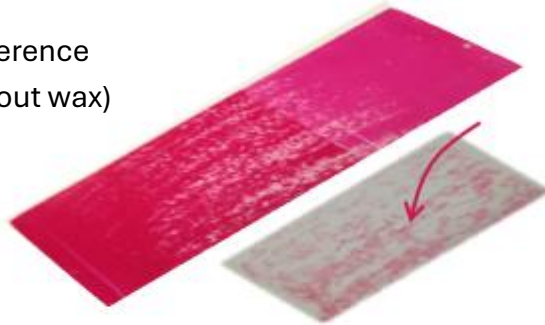

MEGH™WAX MPO 416
oxidized LLDPE wax
1,5% dry base



MEGH™WAX MPO 216
oxidized LDPE wax
1,5% dry base

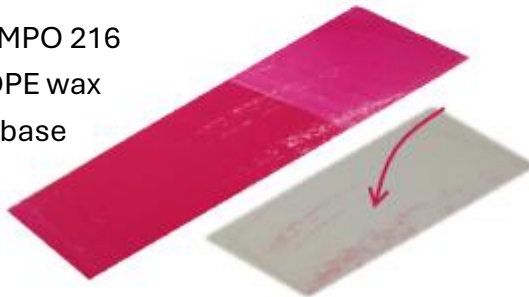

MEGH™WAX MPO 318
oxidized HDPE wax
1,5% dry base

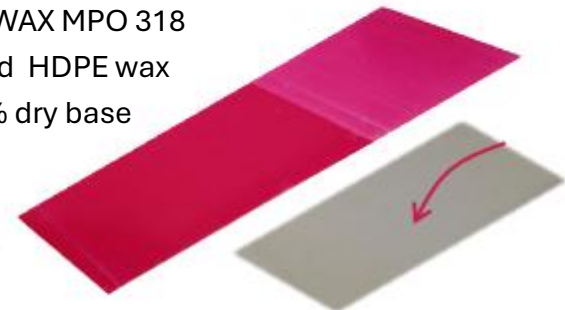

Rub resistance

Mechanical Resistance vs. Wax Molecular Weight

(PE waxes ≠ molecular weight)

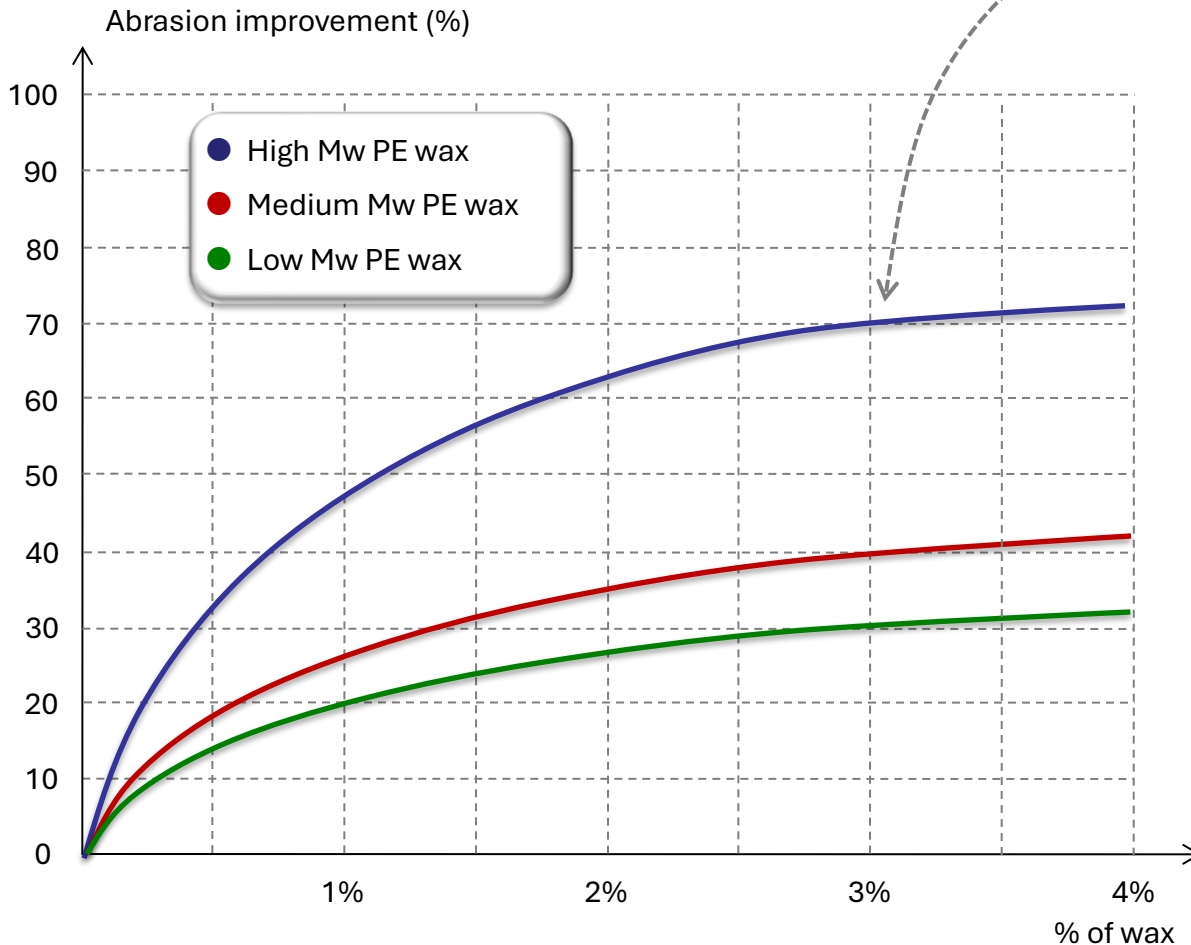

important notes :



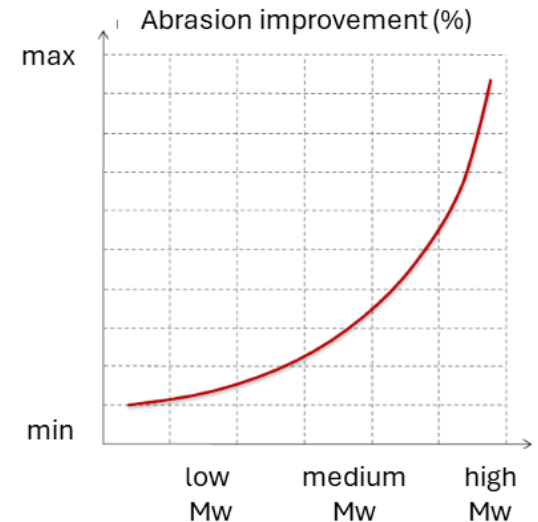

- ✓ above 3% the abrasion resistance improvement is minimal.
- ✓ above 4% other kind of problems can happen , like layers' adhesion , block and gloss reduction.
- ✓ the abrasion resistance increase with an increase of PE wax Mw
HDPE >> LLDPE >> LDPE





Abrasion, Rub & Wear resistance

MEGH has a range of micronized waxes to enhance Abrasion/Rub & Wear resistances in SB coatings:

MEGH Product	Composition		Bio degradable	Bio based
MEGH™PRINT W 1000 F	Polypropylene wax (D50 ~ 8μ – 10μ)	100%	✓	✗
MEGH™PRINT P 0400 EF	Polyolefin wax (D50 ~ 5μ – 6μ)	100%	✓	✗
MEGH™PRINT P 0400	Polyolefin wax (D50 ~ 8μ – 10μ)	100%	✓	✗
MEGH™PRINT P 0900 EF	Polyolefin wax (D50 ~ 5μ – 6μ)	100%	✓	✗
MEGH™PRINT P 0900	Polyolefin wax (D50 ~ 8μ – 10μ)	100%	✓	✗
 ECOWAX™PRINT P 0400 EF	Polyolefin wax (D50 ~ 5μ – 6μ)	100%	✓	✓
 ECOWAX™PRINT P 0400	Polyolefin wax (D50 ~ 8μ – 10μ)	100%	✓	✓
 ECOWAX™PRINT P 0900 EF	Polyolefin wax (D50 ~ 5μ – 6μ)	100%	✓	✓
 ECOWAX™PRINT P 0900	Polyolefin wax (D50 ~ 8μ – 10μ)	100%	✓	✓

Biodegradability test according OECD 301 B normative / Bio-based according ASTM method D6866-24



















IMPORTANT : Above we have some examples about MEGH’s micronized waxes and emulsions range, to achieve the whole micronized waxes line, please contact our technical staff or look at our Micronized Waxes brochure for more information’s.

SB = Solvent based systems



Abrasion, Rub & Wear resistance

MEGH has a range of micronized waxes to enhance Abrasion/Rub & Wear resistances in SB coatings:

MEGH Product	Composition		Bio degradable	Bio based
 MEGH TM PRINT N 120 EF	Modified Rice Bran wax (D50 ~ 5μ – 6μ)	100%		
 MEGH TM PRINT N 120	Modified Rice Bran wax (D50 ~ 8μ – 10μ)	100%		
 MEGH TM PRINT N 350 EF	Rice Bran wax (D50 ~ 5μ – 6μ)	100%		
 MEGH TM PRINT N 350	Rice Bran wax (D50 ~ 8μ – 10μ)	100%		
 MEGH TM PRINT N 500 EF	HCO wax (D50 ~ 5μ – 6μ)	100%		
 MEGH TM PRINT N 500	HCO Bran wax (D50 ~ 8μ – 10μ)	100%		

Biodegradability test according OECD 301 B normative / Bio-based according ASTM method D6866-24

IMPORTANT : Above we have some examples about MEGH’s micronized waxes and emulsions range, to achieve the whole micronized waxes line, please contact our technical staff or look at our *Micronized Waxes brochure* for more information’s.

SB = Solvent based systems



Abrasion, Rub & Wear resistance

MEGH has a range of wax emulsions to enhance Abrasion/Rub & Wear resistances in WB coatings:

MEGH Product	Composition		Bio degradable	Bio based
MEGH [™] PRINT E 5	Polypropylene emulsion	40%		
MEGH [™] PRINT E 10	LDPEOx emulsion	35%		
MEGH [™] PRINT E 216	LDPEOx emulsion	35%		
MEGH [™] PRINT E 21	LLDPEOx emulsion	35%		
MEGH [™] PRINT E 416	LLDPEOx emulsion	35%		
MEGH [™] PRINT E 619	HDPEOx emulsion (food contact)	35%		
MEGH [™] PRINT E 318	HDPEOx emulsion	35%		

Biodegradability test according OECD 301 B normative / Bio-based according ASTM method D6866-24

IMPORTANT : Above we have some examples about MEGH's wax emulsions range, to achieve the whole wax emulsions line, please contact our technical staff or look at our Micronized Waxes brochure for more information's.

WB = Water based systems

Mar resistance

- “Mar resistance” is a generic concept of paint surface damage and may sometimes be confused with scratch resistance. Is the surface ability to retain gloss even over an action of a compression force.
- It is obtained by the process of branding the surface via compression and then measuring the gloss of the part that has undergone compression, with a Glossmeter , and compare the results obtained in this area with the gloss obtained in a region of the surface that has not undergone compression .
- **Is a test used to evaluated the coating superficial layers.**



Instrument for testing Mar Resistance of coatings according ASTM D5178

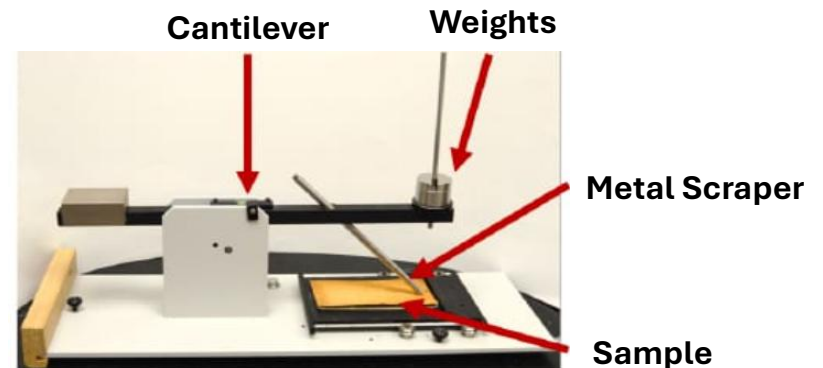

Increasing Force →



The use of wax will cause, that wax will act as a lubricant aid in the surface coating preventing the damage cause by compression, avoiding that the same goes into the resin.



Scratch resistance

- **A surface is damaged by a friction of a thin material causing a risk that can be deep in and as a result usually leaves the surface with a white spot into the “cut”.**



machine used
to measure
scratch
“sclerometer”

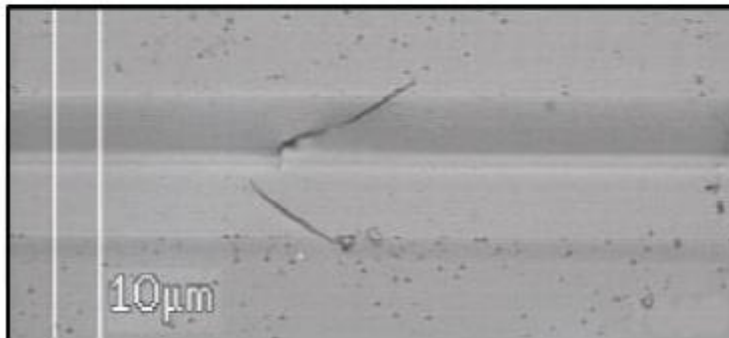

*microphotos of a
scratch in a surface*

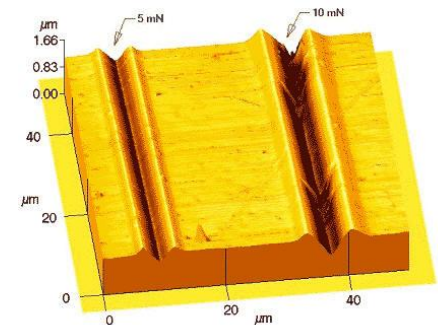



Scratch resistance

- We can measure the scratch resistance of a surface using a machine called sclerometer, where a coating film is submitted by a spin action using a preset weight.



machine used to measure scratch
"sclerometer"

Scratch resistance test

using a preset weight in sclerometer until there is a risk in the emulsion film,
special wax emulsion (25% solids)
film thickness = 100 microns

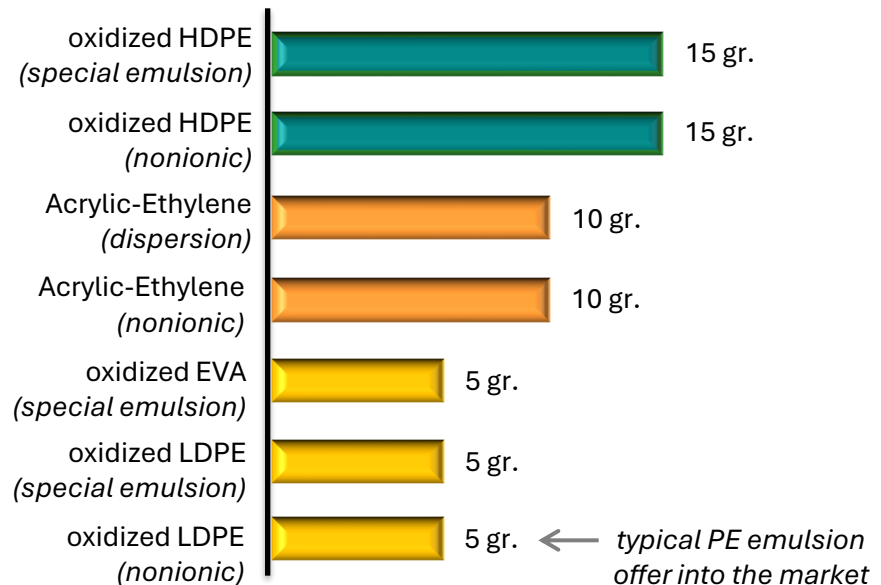
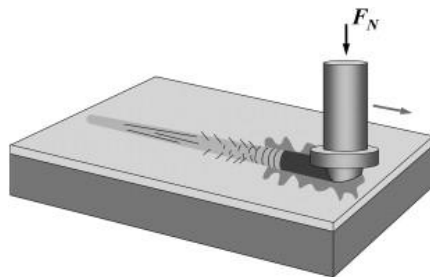























Soft scratch (Writing resistance)

- **A surface can be damage by a friction of a thin material like a long nail.**
- To measure this tinny damage into a surface, the weight used in these kind of test are lower than in the scratch, abrasion and mar resistance tests.
- **Normally we use the pencil hardener test to do it.**



Mar, Scratch & Writing resistance

MEGH has a range of micronized waxes to enhance Resistances in SB coatings:

MEGH Product	Composition		Bio degradable	Bio based
MEGH™PRINT P 0400 EF	Polyolefin wax (D50 ~ 5μ – 6μ)	100%		
MEGH™PRINT P 0400	Polyolefin wax (D50 ~ 8μ – 10μ)	100%		
MEGH™PRINT P 0900 EF	Polyolefin wax (D50 ~ 5μ – 6μ)	100%		
MEGH™PRINT P 0900	Polyolefin wax (D50 ~ 8μ – 10μ)	100%		
 ECOWAX™PRINT P 0400 EF	Polyolefin wax (D50 ~ 5μ – 6μ)	100%		
 ECOWAX™PRINT P 0400	Polyolefin wax (D50 ~ 8μ – 10μ)	100%		
 ECOWAX™PRINT P 0900 EF	Polyolefin wax (D50 ~ 5μ – 6μ)	100%		
 ECOWAX™PRINT P 0900	Polyolefin wax (D50 ~ 8μ – 10μ)	100%		



















Biodegradability test according OECD 301 B normative / Bio-based according ASTM method D6866-24

IMPORTANT: Above we have some examples about MEGH's micronized waxes range, to achieve the whole micronized waxes line, please contact our technical staff or look at our Micronized Waxes brochure for more information's.

SB = Solvent based systems

Mar, Scratch & Writing resistance

MEGH has a range of micronized waxes to enhance Resistances in coatings:

MEGH Product	Composition		Bio degradable	Bio based
 MEGH™PRINT N 120 EF	Modified Rice Bran wax (D50 ~ 5μ – 6μ)	100%		
 MEGH™PRINT N 120	Modified Rice Bran wax (D50 ~ 5μ – 6μ)	100%		
 MEGH™PRINT N 350 EF	Rice Bran wax (D50 ~ 5μ – 6μ)	100%		
 MEGH™PRINT N 350	Rice Bran wax (D50 ~ 8μ – 10μ)	100%		
 MEGH™PRINT N 500 EF	HCO wax (D50 ~ 5μ – 6μ)	100%		
 MEGH™PRINT N 500	HCO Bran wax (D50 ~ 8μ – 10μ)	100%		

Biodegradability test according OECD 301 B normative / Bio-based according ASTM method D6866-24

IMPORTANT: Above we have some examples about MEGH's micronized waxes range, to achieve the whole micronized waxes line, please contact our technical staff or look at our Micronized Waxes brochure for more information's.

SB = Solvent based systems



Mar, Scratch & Writing resistance

MEGH has a range of wax emulsions to enhance Resistances in coatings:

MEGH Product	Composition		Bio degradable	Bio based
MEGH TM PRINT E 318	HDPEOx emulsion	35%		
MEGH TM PRINT E 128	EVAOx emulsion	35%		
MEGH TM PRINT E 21	LLDPEOx emulsion	35%		
MEGH TM SPERSE AC 5120 A 25	EAA dispersion	25%		
MEGH TM WAX AC 540 N 30	EAA emulsion	30%		

Biodegradability test according OECD 301 B normative / Bio-based according ASTM method D6866-24

IMPORTANT : Above we have some examples about MEGH's waxes emulsions & dispersions range, to achieve the whole waxes emulsions & dispersions line, please contact our technical staff for more information's.

WB = Water based systems

Dirt pick up resistance

- **Is the coating ability do not retain dirt on it surface.**
- Maximizing dirt-pickup resistance (DPUR) is a key requirement for many exterior coatings.
- While it is generally known that higher glass transition temperature (T_g) resins impart improved DPUR due to a harder film that is formed, stricter VOC regulations have resulted in the use of lower T_g resins in traditional exterior architectural coatings.
- While it is generally known that higher glass transition temperature (T_g) resins impart improved DPUR due to a harder film that is formed, stricter VOC regulations have resulted in the use of lower T_g resins in traditional exterior architectural coatings.
- **Hard waxes are the best choice to maximizing dirt-pickup resistance (DPUR).**

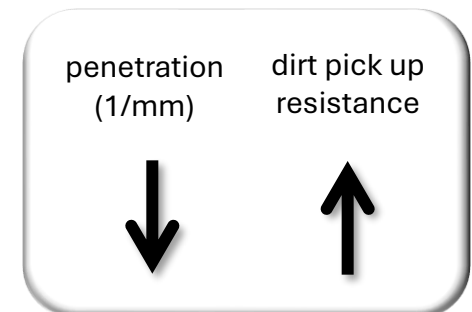
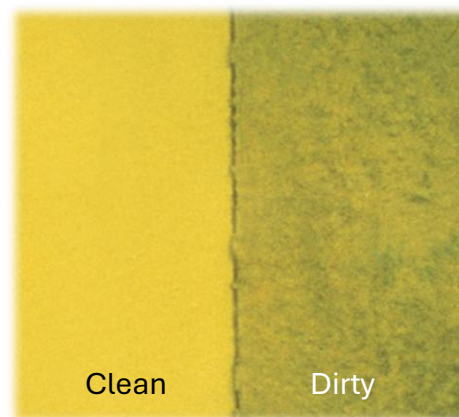

In the above example resins of varying T_g values and as expected, the higher T_g resin resulted in the greatest improvement in DPUR, this is common in systems that require a low- T_g resin, such as elastomeric coatings.



Dirt pick up resistance

MEGH has a range of micronized waxes to avoid dirty pick-up in SB coatings:



MEGH Product	Composition		Bio degradable	Bio based
MEGH™PRINT P 0900 EF	Polyolefin wax (D50 ~ 5µ – 6µ)	100%	✓	✗
MEGH™PRINT P 0900	Polyolefin wax (D50 ~ 8µ – 10µ)	100%	✓	✗
MEGH™PRINT W 1000 F	Polypropylene wax (D50 ~ 8µ – 10µ)	100%	✓	✗
MEGH™PRINT B 1110	EBS wax (D50 ~ 8µ – 10µ)	100%	✓	✓
MEGH™PRINT PR range	Modified Polyolefin wax (D50 ~ 8µ – 10µ)	100%	✓	✗

Biodegradability test according OECD 301 B normative / Bio-based according ASTM method D6866-24





IMPORTANT : Above we have some examples about MEGH’s micronized waxes range, to achieve the whole micronized waxes line, please contact our technical staff or look at our Micronized Waxes brochure for more information’s.

SB = Solvent based systems



Dirt pick up resistance

MEGH has a range of micronized waxes to avoid dirty pick-up in WB coatings:

MEGH Product	Composition		Bio degradable	Bio based
MEGH [™] PRINT E 5	Polypropylene emulsion	40%		
MEGH [™] PRINT E 318	HDPEOx emulsion	35%		

Biodegradability test according OECD 301 B normative / Bio-based according ASTM method D6866-24

IMPORTANT : Above we have some examples about MEGH's micronized waxes range, to achieve the whole micronized waxes line, please contact our technical staff or look at our Micronized Waxes brochure for more information's.

WB = Water based systems





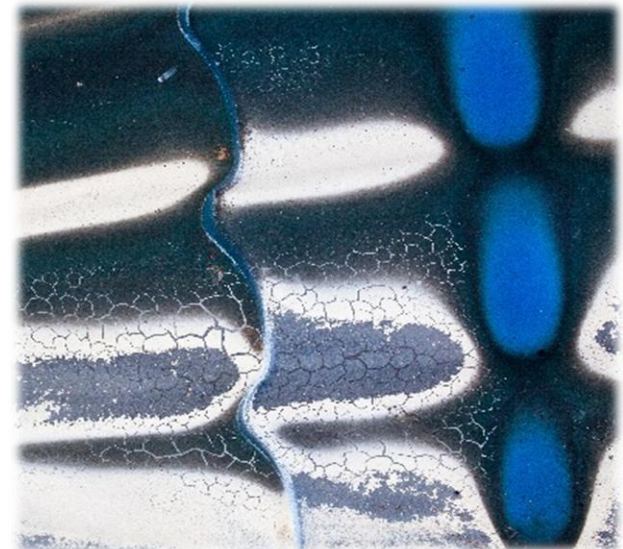
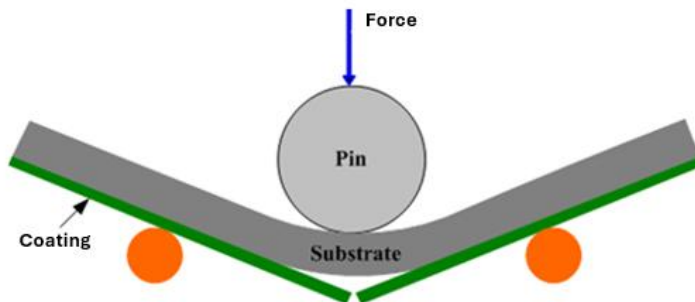





Flexibility

- Flexibility is an important mechanical properties of coating and paint formulations that influence the final performance and contribute to coating longevity.
- **It is very linked to the type of resin used; a flexible wax can help with the performance of coating.**
- **Some examples of flexibility in coatings :**
 1. To achieve good outdoor durability of coated wooden substrates, the coating must be **flexible** enough to compensate for the **changing wood dimensions** due to temperature or humidity variations.
 2. Roofing materials **expand and contract with temperature changes**, so flexible coatings are essential for waterproofing and protection.
 3. Exterior walls, especially in areas with seismic activity or extreme weather, flexible coatings can prevent cracking and damage.



Flexibility

MEGH has a range of waxes to help enhancing the flexibility in SB coatings:

MEGH Product	Composition		Bio degradable	Bio based
MEGH™WAX SPA 170/5	Synthetic Microcrystalline wax	100%		
MEGH™WAX Microflex 250	Synthetic Microcrystalline wax	100%		
MEGH™WAX Microflex 500	Synthetic Microcrystalline wax	100%		
MEGH™WAX EVA 060	EVA wax (8% EVA)	100%		
MEGH™WAX EVA 090	EVA wax (8% EVA)	100%		

Biodegradability test according OECD 301 B normative / Bio-based according ASTM method D6866-24

IMPORTANT : Above we have some examples about MEGH's waxes range, to achieve the waxes line, please contact our technical staff for more information's.

SB = Solvent based systems



Stain resistance

- **Stain-resistant coatings create a protective layer that prevents liquids, oils & greases from being absorbed into the surface.**
- The coating causes liquids and oils to bead up and roll off, reducing maintenance costs.
- What is stain blocking in paint?
- There is also stain-blocking primers, that are used to cover stains such as watermarks, nicotine, tar, markers, smoke, and prevent them bleeding through newly applied layers of paint.
- They also provide adhesion over problematic surfaces, giving better film leveling, and durability.



untreated

treated





Stain resistance

• General Stain-resistant coatings can include:

- Polyester polyols
- Silicone components
- Crosslinkers

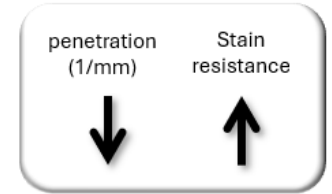

• Some stain-resistant coatings contain Polyfluoroalkyl Substances (PFAs) and Perfluorochemicals (PFCs), which may pose health risks

MEGH has a range of emulsions & dispersions waxes to enhance stain resistance in WB coatings:

MEGH Product	Composition		Bio degradable	Bio based
MEGH™SPERSE AC 5120 A 25	EAA dispersion (AA) = 15,0%	25%	✓	✗
MEGH™COAT AEP 2120	EAA dispersion (AA) = 20,0%	21%	✓	✗
MEGH™COAT AEP 2117	EAA dispersion (AA) = 17,5%	21%	✓	✗
MEGH™COAT AEP 2115	EAA dispersion (AA) = 15,0%	21%	✓	✗

Biodegradability test according OECD 301 B normative / Bio-based according ASTM method D6866-24

IMPORTANT : Above we have some examples about MEGH’s waxes emulsions & dispersions range, to achieve the whole waxes emulsions & dispersions line, please contact our technical staff for more information’s.

WB = Water based systems

Chemical resistance

- **Chemical resistance (CR) can be defined as the ability of a substance to endure itself from chemical attack for a specific period of time and temperature.**
- Therefore, materials with high CR are less likely to corrode.
- Generally used for applications that require exposure to acids, bases, solvents, and other industrial chemicals.
- One important CR is the chemical resistance to salt spray, which is a material's ability to resist corrosion from salt-laden water or air.
- **It's a key factor in determining the lifespan of materials used in coastal areas or industrial settings.**

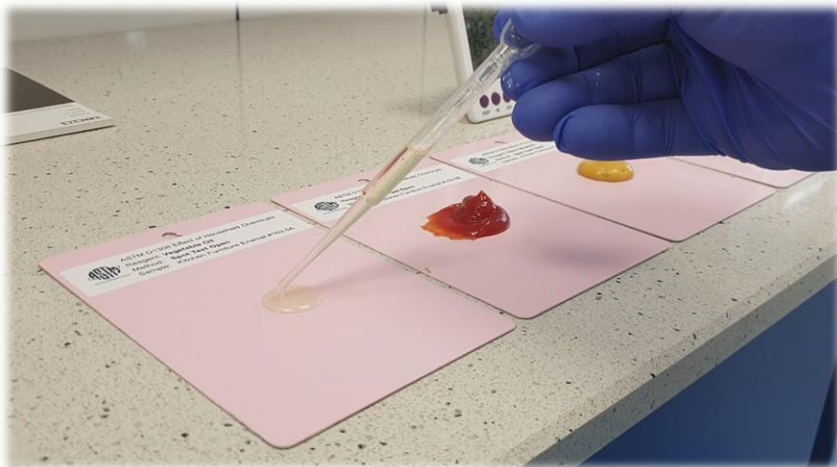

Resistance to Household chemicals



Resistance to Industrial Chemicals

Chemical resistance – Salt Spray

- Salt spray resistance is a coating's ability to withstand salt-laden environments without deteriorating.
- **Coatings with high salt spray resistance are more likely to protect against corrosion, extending the lifespan of metal structures.**

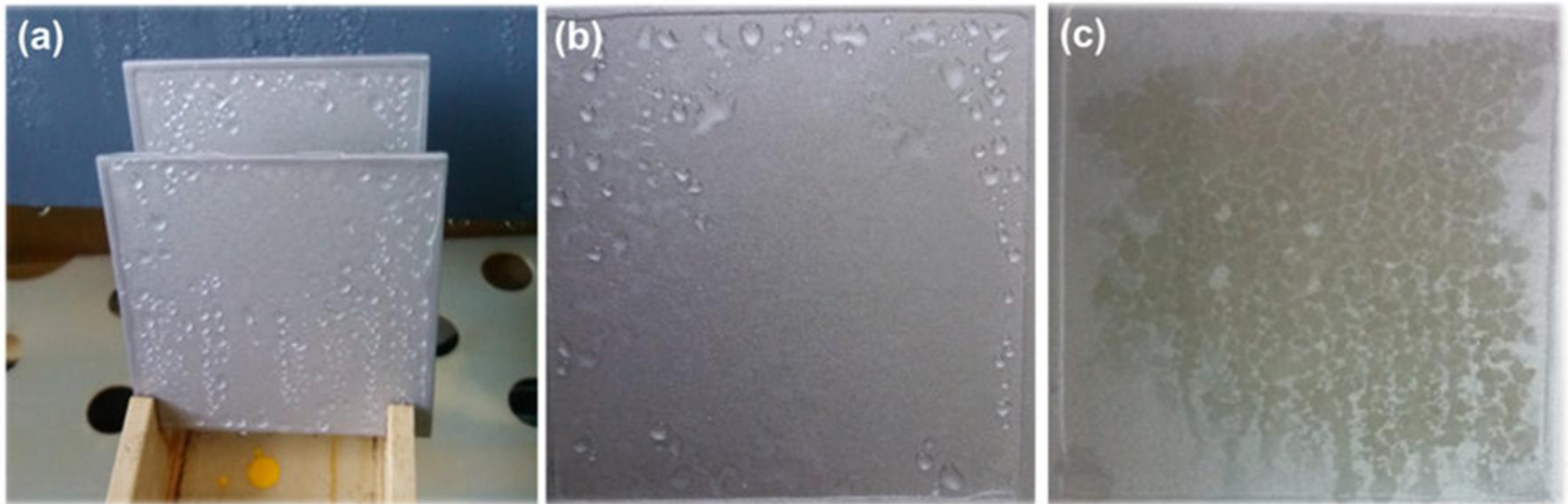

The picture of coating salt spray testing:

(a) before the salt spray test

(b) the coating with a coating after 300 h salt spray testing

(c) the coating with the same coating after 500 h salt spray testing

Chemical resistance – Salt Spray

- Salt spray resistance is a coating's ability to withstand salt-laden environments without deteriorating.
- **Coatings with high salt spray resistance are more likely to protect against corrosion, extending the lifespan of metal structures.**

Time (Hours)	Acrylic resin Blank	Acrylic resin + 5% GCM	Acrylic resin + 5% GCM & driers	Acrylic resin + 7,5% GCM	Acrylic resin + 7,5% GCM & driers	Acrylic resin + 10% GCM	Acrylic resin + 10% GCM & driers
0							
84 3,5 days							
168 7 days							

Another Salt Spray test using the "X" configuration and comparing the corrosion in a coating with acrylic resin + GCM resin additions



Chemical resistance

MEGH has a range of emulsions & dispersions waxes to enhance Chemical resistance in WB coatings:

MEGH Product	Composition		Bio degradable	Bio based
MEGH [™] SPERSE AC 5120 A 25	EAA dispersion (AA) = 15,0%	25%		
MEGH [™] COAT AEP 2120	EAA dispersion (AA) = 20,0%	21%		
MEGH [™] COAT AEP 2117	EAA dispersion (AA) = 17,5%	21%		
MEGH [™] COAT AEP 2115	EAA dispersion (AA) = 15,0%	21%		

Biodegradability test according OECD 301 B normative / Bio-based according ASTM method D6866-24

IMPORTANT: Above we have some examples about MEGH's micronized waxes range, to achieve the whole micronized waxes line, please contact our technical staff or look at our *Micronized Waxes brochure* for more information's.

WB = Water based systems

Wet adhesion

- Very important concept in external coatings
- **Wet adhesion measures the efficiency of anchoring the paint to the substrate despite the damp conditions and the external environment.**
- **Adhesion promoters can help improve adhesion by forming a strong bond between the coating and the substrate.**



Measuring the Wet Adhesion

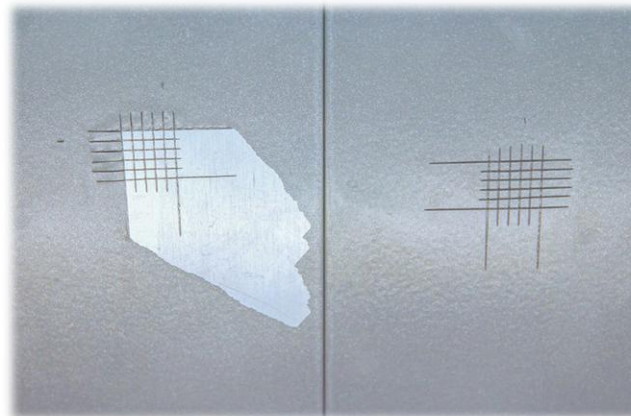

Poor Wet Adhesion x Good Wet Adhesion

Wet adhesion



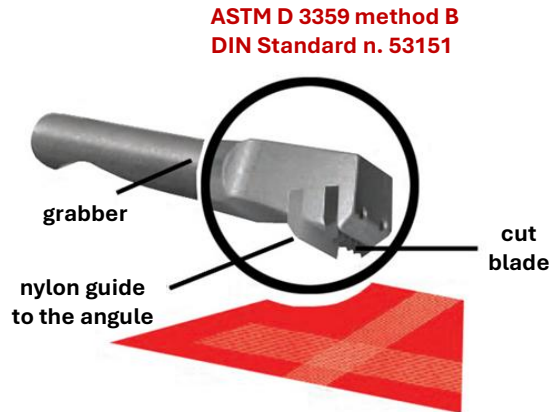
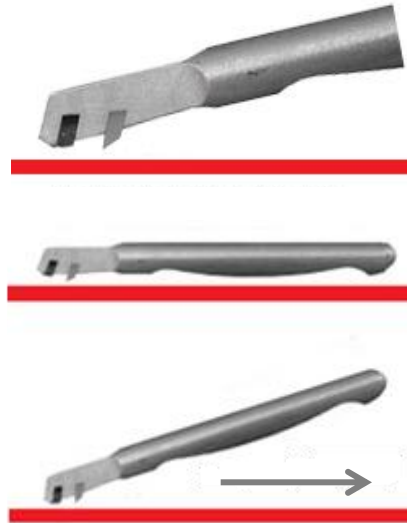

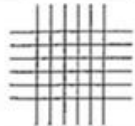
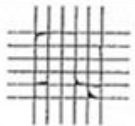
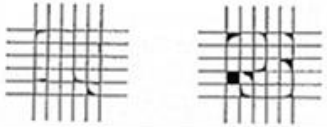
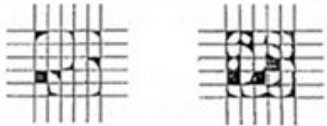
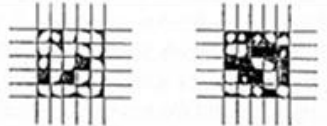
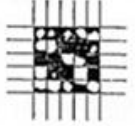



- Wet adhesion can be measure by the following test :



classification	% removed area	cross-cut area surface where occur the formation os peel among 6 cuts
5B	0% non	
4B	lower 5%	
3B	5% - 15%	
2B	15% - 30%	
1B	35% - 45%	
0B	greater 60%	

Wet adhesion

MEGH has a range of emulsions & dispersions waxes to enhance the Wet Adhesion in WB coatings:

MEGH Product	Composition		Bio degradable	Bio based
MEGH™PRINT E 5	Polypropylene emulsion	40%		
MEGH™COAT AEP 2120	EAA dispersion (AA) = 20,0%	21%		
MEGH™COAT AEP 2117	EAA dispersion (AA) = 17,5%	21%		
MEGH™COAT AEP 2115	EAA dispersion (AA) = 15,0%	21%		

Biodegradability test according OECD 301 B normative / Bio-based according ASTM method D6866-24

IMPORTANT : Above we have some examples about MEGH's micronized waxes range, to achieve the whole micronized waxes line, please contact our technical staff or look at our *Micronized Waxes brochure* for more information's.

WB = Water based systems



Wet Edge Retention

- **Wet Edge Retention** is the time needed, after a paint layer, to apply a second or third layer, without any damage into the original layer.
- This test can show the **paint “anchor”** powder over a substrate.

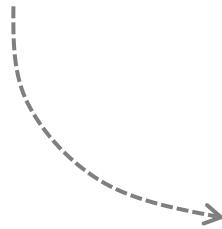

Non-Optimal Paint Anchor Profile

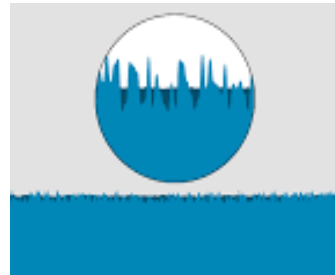

Optimal Paint Anchor Profile

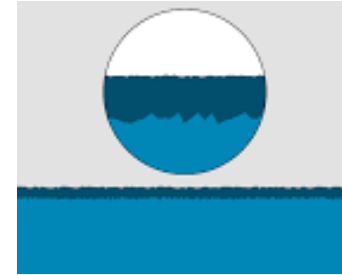



Wet Edge Retention

MEGH has a range of emulsions & dispersions waxes to enhance the Wet Edge Retention in WB coatings:

MEGH Product	Composition		Bio degradable	Bio based
MEGH [™] SPERSE AC 5120 A 25	EAA dispersion (AA) = 15,0%	25%		
MEGH [™] COAT AEP 2120	EAA dispersion (AA) = 20,0%	21%		
MEGH [™] COAT AEP 2117	EAA dispersion (AA) = 17,5%	21%		
MEGH [™] COAT AEP 2115	EAA dispersion (AA) = 15,0%	21%		

Biodegradability test according OECD 301 B normative / Bio-based according ASTM method D6866-24

IMPORTANT : Above we have some examples about MEGH's micronized waxes range, to achieve the whole micronized waxes line, please contact our technical staff or look at our Micronized Waxes brochure for more information's.

WB = Water based systems



Wall Putty

- **Wall putty for home consists of white cement that acts as a base paint for your wall and is the preliminary step to ensure a smooth painting process.**
- This cement-based powder has high plasticity and helps you to fill in any cracks, dents or holes in the wall to ensure a smooth surface at the time of painting.
- Most professional painters tend to apply two coats of putty before starting to paint.
 - The first coat is meant to fill any imperfections
 - The second one ensures that the wall and coated surface are properly lined up.
- The good thing is that wall putty is extremely versatile.





Wall Putty

1. Wall putty can be divided into 2 categories :

- **Interior wall putty**
- **External wall putty**

2. The main difference among them is the type of resin :

- **Interior walls → PVA resins**
- **Exterior walls → Acrylic resins**



3. The primary difference between interior and exterior wall putty is their ability to withstand harsh weather conditions, with exterior putty being specifically designed to resist :

- Moisture
- Sunlight
- Temperature fluctuations

while interior putty is formulated for dry indoor environments and is typically less durable against the elements



PVA Putty – Internal wall putty

- **The internal wall putty is basically made with PVA resins.**
- The interior wall putty is formulated for dry indoor environments and is typically less durable than external.
- One property very desirable in wall putties is the weather/water resistance.
- This kind of property can be achieved using different kind of wax emulsions.
- **MEGH has a very good range of wax emulsions to enhance the**
 - Weather/Water resistance
 - Drew effect

sold under the names:

MEGH™WAX

MEGH™PRINT

MEGH™SPERSE





PVA Putty – Internal wall putty

- Another interesting consequence of using wax emulsions into wall putties, especially internal PVA wall putties is the putty's aspect has a **creamier appearance** than the putties with no wax emulsion.
- This makes it easier and more enjoyable to apply over the wall.
- **Example with MEGH™WAX EEW 5030 :**



PVA internal wall putty, **NO ADDITIVE**



PVA internal wall putty, **with 0,7% of MEGH™WAX EEW 5030, an Ester wax emulsion 45%,**



Application of MEGH™WAX EEW 5030, an Ester wax emulsion 45%, in a PVA internal wall putty

Very Important :

The wax emulsion quantity to be add into wall putty can not be so high, otherwise it will make it difficult to anchor the subsequent paints layers later.

In the quantity to be added always consider the relative air humidity at the place of application.

Humidity areas ↑ wax emulsion | Dry areas ↓ wax emulsion



PVA Putty – Internal wall putty

MEGH has a range of wax emulsions & dispersions to enhance hydrophobicity/dew effect in WB coatings:

MEGH Product	Composition		Bio degradable	Bio based
MEGH TM PRINT E 12	Paraffin emulsion	45%		
MEGH TM WAX EEW 5030	Natural Ester wax emulsion	45%		
MEGH TM SPERSE A 1540	Modified Polyethylene dispersion	40%		
MEGH TM SPERSE BIO 59138	Vegetable Ester wax dispersion	45%		
MEGH TM SPERSE BIO 59238	Vegetable Ester wax dispersion	45%		
MEGH TM SPERSE BIO 9645	Vegetable Rice Bran wax dispersion	45%		

Vegetable Ester wax emulsion = Ester waxes based on vegetable raw materials from different sources like soy, palm, sunflower, rapeseed, coconut sources; alone or in mixtures or reactions among them.

Biodegradability test according OECD 301 B normative / Bio-based according ASTM method D6866-24

IMPORTANT : Above we have some examples about MEGH’s wax emulsions & dispersions range, to achieve the whole waxes emulsions & dispersions line, please contact our technical staff for more information’s.

WB = Water based systems



Acrylic Putty – External wall putty

- The external wall putty is basically made with acrylic resins.
- The exterior wall putty must be able to withstand harsh weather conditions, with exterior putty being specifically designed to resist :
 - Moisture
 - Sunlight
 - Temperature fluctuations
- The use of wax emulsions into external wall putties, is not so common as in internal wall putties due the fact of the resin content in external wall putties are higher and already achieve a good weather/water resistance, but even in this case, the effectiveness of wax emulsion can be proven, as we can see below :



Acrylic external wall putty, **NO ADDITIVE**

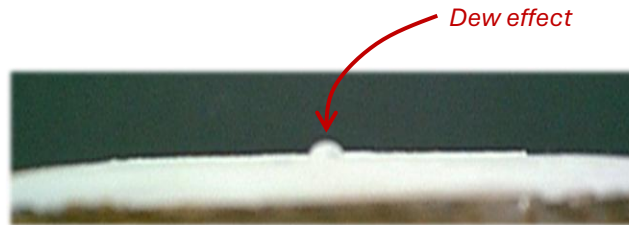

Acrylic external wall putty, **with 1,0% of MEGH™ WAX EEW 5030, an Ester wax emulsion 45%,**



Dew effect



Acrylic Putty – External wall putty

- Using acrylic resins to manufacture external wall putty make it resistance to all weather conditions, but this putty will be very dense and hard **making it difficult to sand.**





Acrylic Putty – External wall putty

- MEGH has a very good additive to **easy the acrylic putty sand process**, it calls :

MEGH[™]SPERSE A 1540

MEGH[™]SPERSE A 1540

Modified Polyethylene Dispersion

Physical chemical properties

Aspect at 25°C	MA009	Milky liquid
Color	MA009	slightly yellow to yellowish
Solids content	MA006	39,0% – 40,0%
pH water solution 10% - 25°C	MA008	9,0 – 12,0

 a super additive
POW!
for your paints



Click on the above QR code and learn a little more about our MEGH[™]SPERSE A 1540 in wall putty sand application



Make a trial with MEGH inside

